



Manual Gauge MD50/MD50D



*photo: MD50D with RC conveyor and inserts

INSTRUCTION MANUAL

Hymark Ltd. – 427 Bark cove– Owensboro, KY 42303
(270) 683-3500 – Fax (270) 683-2500
www.kentuckygauge.com

1. Intended Use

The only acceptable use for the MD50/D is as a length gauging system. Never place any material on the conveyor / table that is not intended to be cut, drilled or fabricated. Any other use is not intended and is a misuse of the gauging system.

Raw material with cross section of	Ø 5 to 110 mm □ 5 to 100 mm
Raw material weight	max. 600lbs (272kg)

1.1 Caveats

Other uses as mentioned above are expressly forbidden. Including but not limited to use as the following:

- Use as a material feed pusher
- Use of the conveyor as a work table

1.2 Workplace

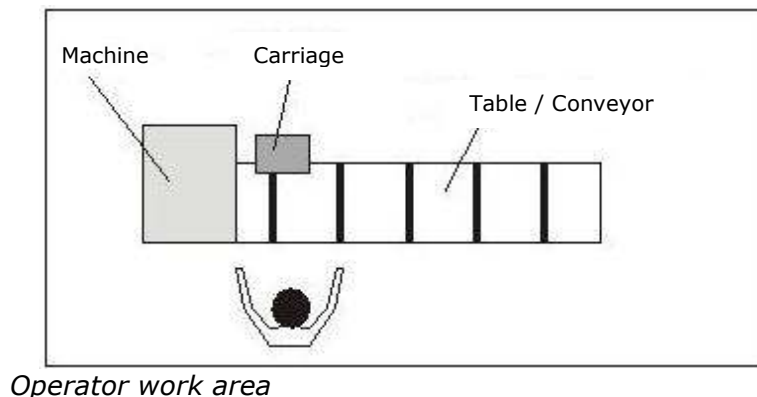

The only acceptable operator location in the work area is standing in front of the control stand on the opposite side of the conveyor (see picture above)

1.3 Danger zones

The moving carrier

The area between the face plate or moving carrier and the saw, drill, puncher or any other machines

These areas are always dangerous and have the potential to harm the operator or others. Use safety precautions when working inside these areas.

2. Basic safety information

2.1 Read and follow information inside this Instruction Manual

This instruction manual, especially the safety hints and precautions must be followed by every person working with this gauge or machine.

Also follow all general plant safety rules and precautions not mentioned in this manual.

2.2 Owner obligations

The owner agrees to only allow the gauge or the machine to be used by qualified and trained persons who

- Have been instructed in general safety rules and precautions

- Have been instructed in the correct use of the gauge and machine

2.3 Operator obligations

All persons working with this gauge and machine agree before operating

- To follow general safety rules

- To read and understand this instruction manual.

2.4 Intended use

The only acceptable use for this gauge is as a length gauging system. Any other use is not intended and is a misuse of the gauging system.

Hymark is not liable for any damages resulting from misuse.

Additionally:

- Following all general safety rules and precautions mentioned in this manual

- Following the maintenance and inspection procedures as mentioned in this manual.

3. Installation

3.1 Conveyor Installation (optional, applicable if conveyor / table is purchased)

- ☞ Assemble the conveyor legs to the appropriate height with the supplied nuts and bolts; typically the leg height is adjusted so that the height of the rollers or tabletop matches that of the machine bed of the saw, drill or punch.
- ☞ Attach the conveyor legs to the conveyor or flat bed with the supplied bolts.

Connect bed to legs



- ☞ Assemble the conveyor legs to the appropriate height with the supplied bolts; typically the leg height is adjusted so that the height of the rollers or tabletop matches that of the machine bed. The socket size for the course leg height adjustment is 9/16.



(Note: Machine may arrive with table mounted to legs)

- ☞ Set the conveyor in place and be sure that it is level and square with the machine.
- ☞ Fasten the table legs to the floor to prevent tipping when the stop system is attached (recommended).

3.2 Attaching rail to conveyor

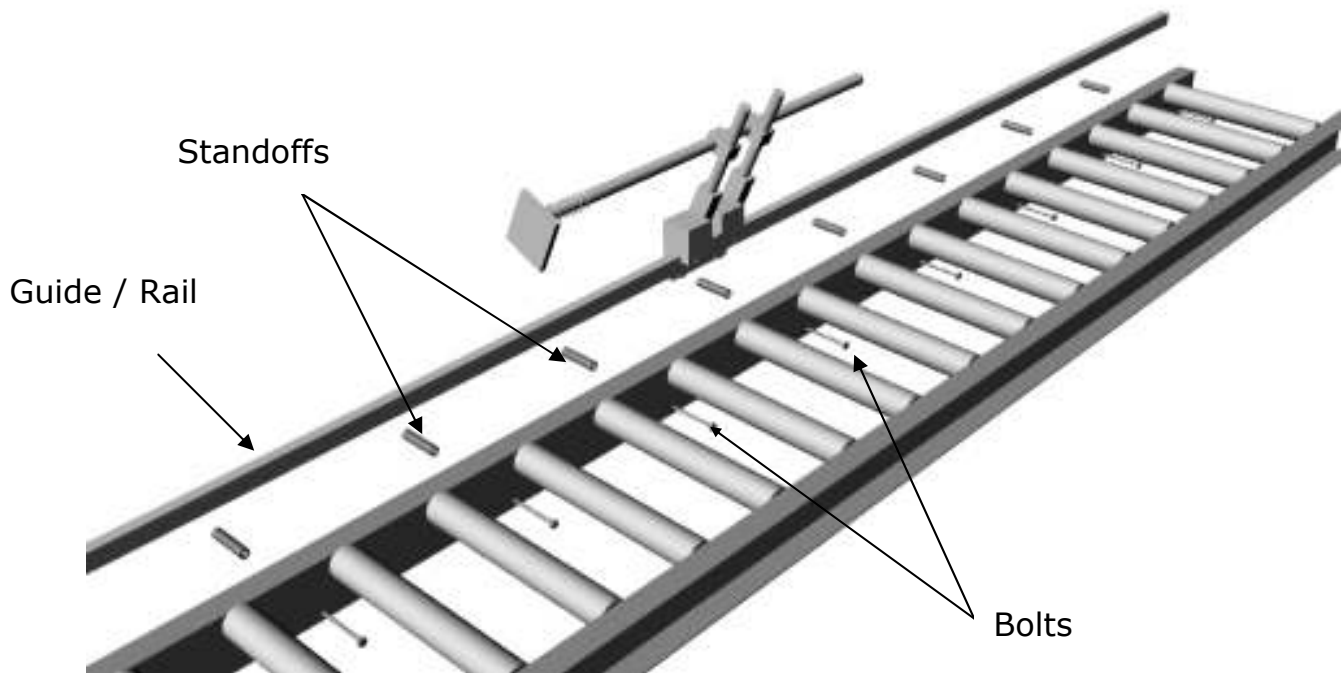

- ☞ Attach the steel guide / rail to the table with the t-nuts, bolts and standoffs (standoffs may be round or square depending on model type).
- ☞ Snap or slide T-nuts into the T-slot facing the conveyor. For the Kentucky Gauge conveyors series RC or RH use one T-nut every 18 inches (recommended). Note: T-nuts may already be inserted in extrusion upon delivery.

T-nuts



Standoffs



- ☞ Mount aluminum extrusion / rail to conveyor by using supplied M8 socket head cap screws with washers and stand-offs. Stand-off length is designed for Kentucky Gauge conveyors series RC and RH.



Note: Do not tighten fully the screws at this point to be able to align the T-nuts with the conveyor mounting holes and to align the aluminum extrusion in X direction when mounted to the conveyor.

- ☞ When all stand-offs of aluminum guide / rail section are mounted, adjust aluminum extrusion in X direction so that end of conveyor is aligned with end of aluminum extrusion and tighten socket head cap screws.
- ☞ If attaching the gauge / steel guide / rail to a non-Kentucky Gauge style conveyor or table, use provided T-nuts, bolts and standoffs as needed.



3.3 Sliding on the carriage assembly / bearing adjustment

- ☞ Remove the end stop bolt and slide the carriage assembly on the steel guide.
Note: if magnetic scale pre-applied (for D version), the bumper stop acts as a pinch point for cover strip termination point. **Do not peel off the cover strip.**

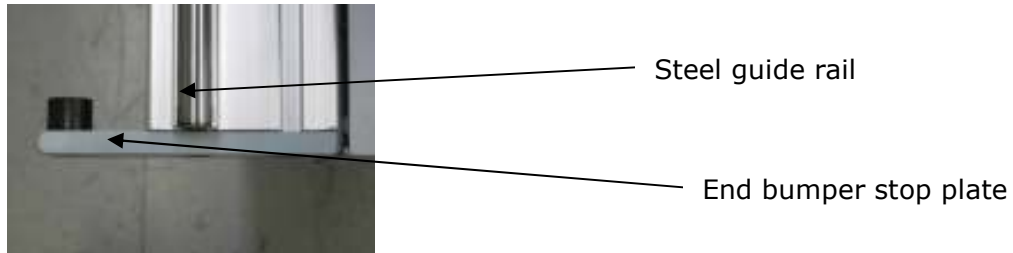

- ☞ Slide carriage carefully on rails so that the two top and bottom rollers of the carriage are running on the double linear guides, be sure to lift the wiper to allow for proper sliding

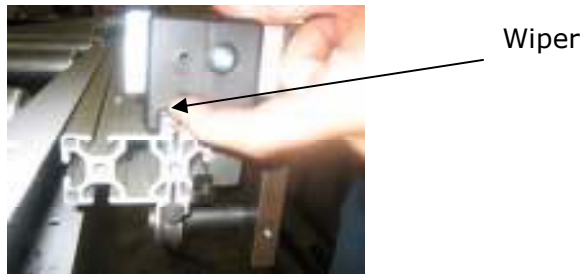

- ☞ While sliding on the carriage make sure to not scratch the surface of the sensor head on the magnetic tape (this is located on the underside of the carriage)
- ☞ Note: the gap between sensor head and magnetic tape scale shall not exceed 0.040in (1mm), adjust if needed to be in range of 0.1mm to 1.0mm (0.004 to 0.040in)

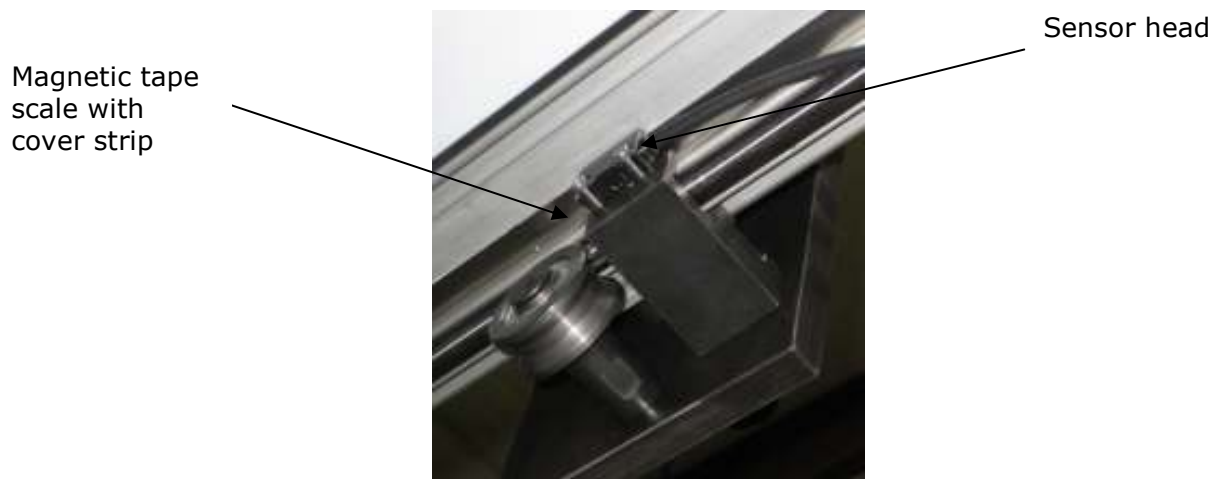

(Note: Machine may arrive with carriage mounted to rail)

- ☞ The bottom roller bearing shafts are eccentric. Adjust the carriage rolling tension by loosening the lower shaft bolt(s) and then tightening or loosening the eccentric shaft. Once the desired tension is set, retighten the shaft bolt. Note: only adjust one shaft / bolt assembly at a time.

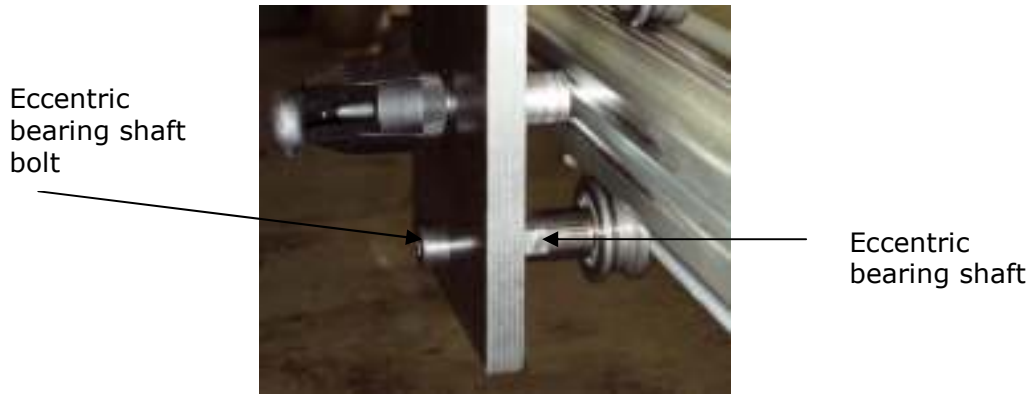

- ☞ The MD50 / MD50D is provided standard with 2 adjustable wings and arm extension with steel faceplate. The contact face plate is adjustable in X, Y, and Z directions via loosening, sliding, repositioning and tightening the T-nut / bolt assembly at the desired locations.



The gauge has a manual arm lift / lower feature for material pass through

4. Basic Operation

4.1A Stop Operation with MD50 tape scale rule (MD50 standard version)

- ☞ When using the MD50 tape scale ruler version, apply the rule scale (via pre-applied adhesive on backing) to the top rail in correspondence to a measured length of your reference position.

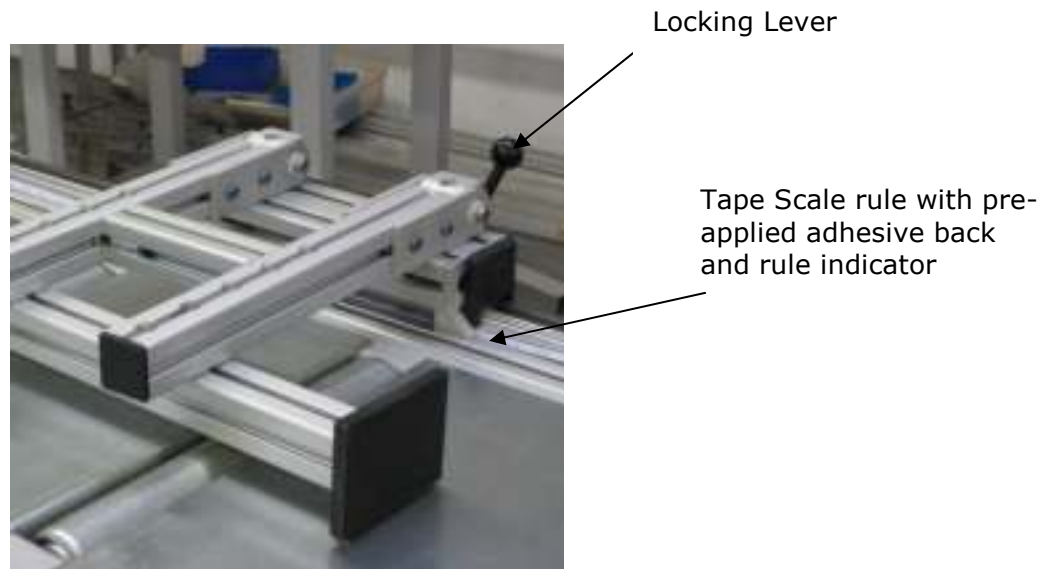

4.1B Stop Operation with Display (applicable to MD50D version only)

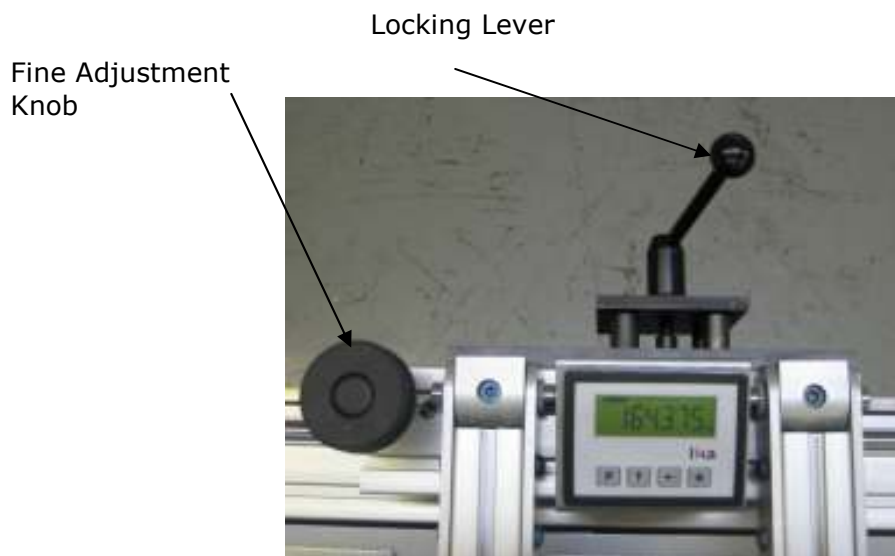

4.2 Set Stop Position

1. Release locking level (see above illustration)
2. Move stop to position using the digital display
3. Rotate Fine Adjustment Knob to adjust position down to 0.001", if necessary(MD50D)
4. Lock locking lever (see above illustration)
5. Note: The LCD is powered via a "C" battery and does not power "off". Battery will need to be replaced approximately every 12 months.

4.3 Function of the keypads

*Complete display manual provided by the LIKA (Display OEM) is attached in rear of manual.



P	:	Program (programming/change parameters)
↑	:	UP (increase value of selected digit)
←	:	Shift left (select digit)
*	:	Save (save data)

4.4 Setting Datum (Referencing) the system

By setting the datum or referencing the system, the operator is setting up the system so that the distance from the stop face to the cutting blade is correctly displayed in the digital readout.

1. Move the stop to a known location using a standard or other suitable method.
2. Press the * button and hold for 3 seconds.
3. The display will show "rESet".
4. Press the * button again to show the current position flashing. Note: at this point the referencing can be cancelled by pressing "P".
5. Press the * button again to confirm the reference reset by displaying "done" momentarily. This will set the display to the pre-entered datum value

4.5 Entering / changing datum value

Push **P** and **↑** buttons together to display datum value "rEF". Use **←** and **↑** keys to change digits to the correct value and save with * button. **Push P button to exit "datum change" mode.** This feature is only enabled if "F_rEF" parameter is set to "yES" (see LD142 manual in rear).

4.6 Setting the Display Mode (switching from inch to metric via keypad)

The display can be easily changed to display inch or metric values by pressing the **←** button for 3 seconds. Note: this feature is active when "F_mmI" parameter is set "yES" (see LD142 manual in rear).

4.7 Changing from Absolute Measuring to Incremental Measuring

The display can be changed from absolute measuring (unit displays actual distance from blade) to incremental or relative measuring (unit displays distance from last position). Pressing the **P** and ***** buttons together toggles these modes. This feature is active only when "F_rEL" is set to "yES". For nearly all applications, absolute measuring will be required. Note: Setting the display to zero in incremental mode is not affecting the real absolute value

***Complete display manual provided by the LIKA (Display OEM) is attached in rear of manual.**

5. Dimensional Drawings for display (in mm)

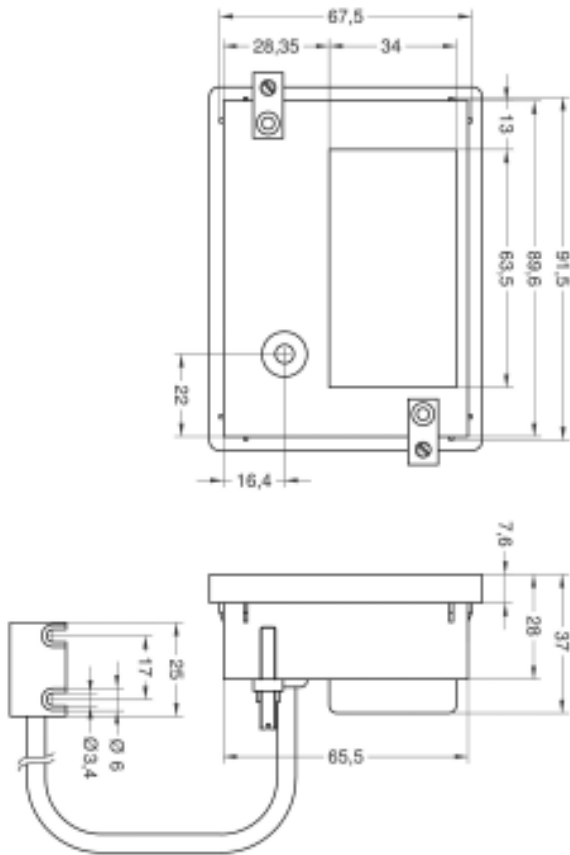

6. Technical Data

LCD display	:	7 digits plus sign symbol , 11 mm high
Battery	:	Commonly available "C" size , 1.5V
Consumption	:	ca 1mA at 1.5V
Operating temperature	:	5°C to 50°C (41°F to 122°F)
Operating Speed	:	max. 2.5m/sec (100in/sec)
Resolution	:	0.001in
Housing	:	Black metal for panel mounting
Dimensions	:	96w x 72h x 40d
Cut Out (mm)	:	94w x 66h
Protection Class	:	IP43

7. Integrated Sensor Specifications

Technical Data:

Cable Length	:	0.1 to 1.5 m
Protection	:	IP67
Operating Temperature	:	5°C - 50°C (41°F-122°F)
Orientation	:	Any
Bend Radius	:	min 60mm (2.5in)
Gap Tape/Sensor	:	max 1mm (0.04in)

8. Maintenance Requirements

Maintenance actions as described in this document should only be done by authorized and trained personal that have become familiar with the Kentucky Gauge equipment. Any questions or inquiries should be directed to our factory technical department at 270-683-3500 ext.114.

Lubricants and Detergents

- ☞ Do not use acids or alkaline solutions
- ☞ Do not use high pressure water jet cleaners
- ☞ Use a light machine oil (i.e. "3 in 1" oil) where lubricating is needed
- ☞ Prior to any maintenance of the Kentucky Gauge or accessories, please ensure the machine is not in operation and corresponding equipment is on "off" position.

Cleaning the roller table

- ☞ Remove chips and grease and any items that would be deemed in the pathway of, or causing an unwanted obstruction of, the gauge arm / carriage. This should be done several times per day when the machine is in use.

Cleaning the magnetic tape scale (underside of the guide rail)

- ☞ Remove chips and grease on the magnetic tape and between reader head and tape. This should be checked on a monthly basis to ensure there is no development of debris or obstruction. If heavy chip or debris accumulation occurs, increase frequency to accommodate suitable maintenance measures. The sensor to scale gap should be within the range of 0.1mm to 1.0mm

Cleaning and maintaining the carriage

- ☞ Do not remove any safety devices.
- ☞ Remove chips and grease and any items that would be deemed in the pathway of, or causing an unwanted obstruction of, the gauge arm / carriage. This should be done several times per day when the machine is in heavy use.
- ☞ Ensure that the hardware connecting the gauge arm to the carriage and the cable track (if applicable) to the carriage are secured. This may be checked on a quarterly basis or implemented in line with the standard preventive maintenance schedules for the other equipment in the facility.

Cleaning the double steel rods on aluminum extrusion

- ☞ You may clean with compressed air along the double steel rods.
- ☞ Add light machine oil lubricant in access of end cap labeled oil. This will keep wipers and steel rods maintained with lubricant. This may be checked on a quarterly basis or implemented in line with the standard preventive maintenance schedules for the other equipment in the facility.

User manual

LD140-M7 + SM25

LD141-M7-R-...

LD142-M7-R-...

Description

This manual describes the LD14x battery display series and the sensors of the SM25 series. The purpose of this system is to display linear or angular displacements on industrial machines and on automation systems. The measurement system includes a battery powered LCD display, magnetic tape and a magnetic sensor. As the sensor is moved along the magnetic tape, it detects the displacement which is shown on the display. The flexibility of the tape allows it to be used for both linear and angular applications.

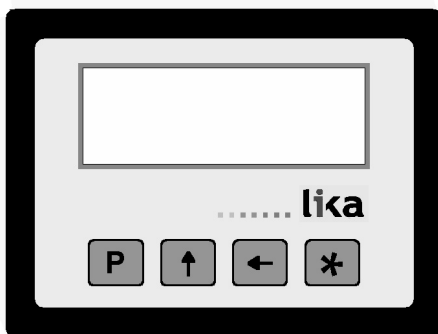

Chapters

- 1 Safety summary
- 2 Identification
- 3 Installation
- 4 Mounting recommendations
- 5 Electrical connections
- 6 Setup
- 7 RS232 serial interface (only with option I1)
- 8 Dimensional drawings and cut-out

1 - Safety summary

We strongly recommend carefully reading this user manual and following the installation guidelines:

- Sensor head should be installed as close as possible to the display.

- Avoid running the sensor cable near high voltage power cables (e.g. drive cables).
- Avoid mounting sensor head near capacitive or inductive noise sources such as relays, motors, and switching power supplies.

Connect according to chapter 5.

2 - Identification

The display and sensor can be identified by the label's data (ordering code, serial number). This information is listed in the delivery document. For technical features please refer to the product catalogue.

3 - Installation

Install the product according to the protection level provided.

Protect the system against knocks, friction, solvents, temperatures under -0°C (32°F) and over $+60^{\circ}\text{C}$ ($+140^{\circ}\text{F}$).

Be sure that the system is mounted where hard or sharp objects (e.g. metal chips) do not come into contact with the magnetic scale and the bottom of the sensor head. If these conditions cannot be avoided provide a wiper or pressurized air.

4 - Mounting recommendations

4.1 Display

Push the display into the cut-out without panel clips.

Install panel clips on the display's housing and screw until fixed and stable.

Power supply by 1.5V commercial battery type C (or AM2 / BABY / LR14 / MN1400 / SP/HP11).

4.2 Magnetic tape

See manual supplied with the magnetic tape.

4.3 Sensor mounting

4.3.1 Sensor SM25-R (rectangular)

Sensor can be fixed by means of two M3 screws over the buttonholes. Make sure that the gap between sensor and tape is in respect with (fig. 1) along the total measuring length. Avoid contact between the parts. You can check planarity and parallelism between sensor and magnetic tape using a feeler gauge.

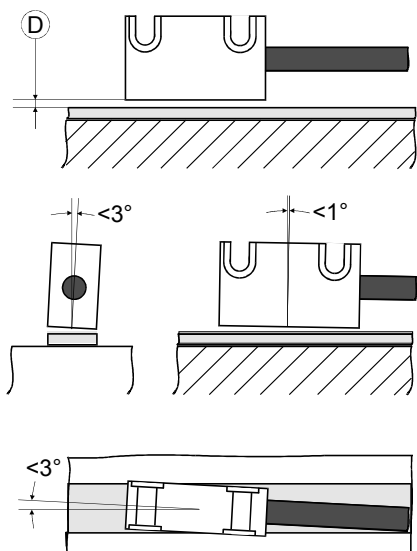

figure 1

D = 0,1 mm - 1,0 mm

4.3.2 Sensor SM25-C (circular)

The sensor can be fixed in a corresponding mounting hole by means of the two nuts. Make sure that the gap between sensor and tape is in respect with (fig. 2) along the total measuring length. **Observe the correct alignment of the marker on the tape.** Avoid contact between the parts. You can check planarity and parallelism between sensor and magnetic tape using a feeler gauge.

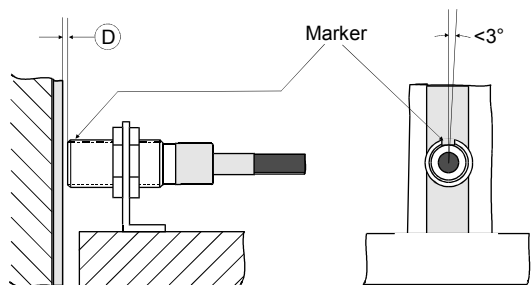

figure 2

D = 0,1 mm - 1,0 mm

5 - Electrical connections

5.1 SM25 sensor (only LD140)

Plug in the sensor's Mini-DIN connector (circular) on backside of the display.

5.2 RS232 serial interface (only with option I1)

Connect PC to LD14x with NULL MODEM COMPUTER AT CROSS OVER cable (9 pin female - 9 pin female) available in commerce.

Electrical cable connection:

Pin PC	Function	Pin LD14x
1		
2	Rx	3
3	Tx	2
4	DTR	6 *
5	GND	5
6	DSR	
7	RTS	8 *
8	CTS	
9		

* Power supply has to be provided to RS232 interface to avoid battery consumption. If not connect to the PC provide power supply (8-15Vdc) to pin 6 or 8. External supply isn't needed if using a Modem computer cable!

6 - Setup

6.1 Key's function

- ↑ : UP (select value)
- ← : Shift links (select digit)
- * : Save (save data)
- P : Program (programming/change parameter)

6.2 Key combinations / Quick functions

6.2.1 Set datum (reference)

Push * key for 3 sec. to access reset function ("rESet" will be displayed).

Push P key to exit function (no reset).

Push * key twice to confirm datum value ("donE" will be displayed).

Display value = rEF + OFS1 + OFSx (where OFSx is the actually set Offset value).

This function is enabled only if "F_rSt" parameter is set "yES".

6.2.2 Incremental measurement

Push P and * key simultaneously to switch from absolute measurement to incremental.

Zero setting in incremental modes (see 6.2.1) does not change absolute value in the background.

The function is enabled only if "F_rEL" parameter is set "yES".

6.2.3 Mm/inch display modes

Mm/inch display modus can be changed by pushing ← key for 3 s. The function is enabled only if "F_mml" parameter is set "yES".

6.2.4 Offset value modification

Push P and ← keys simultaneously to display 1. Offset value (OFS1). Use ← and ↑ keys to change value and save with * key. Further Offset values OFS2 and OFS3 can be changed only in setup menu. Offset function is enable if "F_oFS" parameter is set "yES".

← key allows to scroll OFS1, OFS2 and OFS3 values.

OFS1 = actual value + OFS1 + rEF

OFS2 = actual value + OFS1 + OFS2 + rEF

OFS3 = actual value + OFS1 + OFS3 + rEF

6.2.4.1 Fractional offset display

The fractional inch display mode allows to set offset values (OFS) in the following way:

- 1st digit blinking → increases 1/64" pushing ↑ key.
- 2nd digit blinking → increases 1/32" pushing ↑ key.
- 3rd digit blinking → increases 1/16" pushing ↑ key.
- 4th digit blinking → increases 1/8" pushing ↑ key.
- 5th digit blinking → increases 1" pushing ↑ key.
- 6th digit blinking → increases 10" pushing ↑ key.

6.2.5 Datum modification

Push simultaneously P and ↑ keys to display datum value rEF. Use ← and ↑ keys to change value and save with * key.

This function is enabled only if "F_rEF" parameter is set "yES".

6.3 Setup / Parameter setting

Push P key for 3 s to enter setup and "SEtUP" is displayed.

Push ↑ key to enter MENU 1 (parameters)

Push * key to enter MENU 2 (RS232 serial interface)

Push P key to access the next Parameter and Parameter setting.

Push P key for 3 s to exit the setup at any point.

6.3.1 Default parameters (factory settings)

All default values are written in **BOLD** characters.

The display can be reset to default parameters with the following procedure:

- take out battery and wait for 10 s.
- while putting in the battery push * key ("dEFFPar" is displayed)

6.3.2 Parameter list MENU 1

Unit Measurement unit [dEC, FrEE, dG1, dG2, ldEC, lfrct]

Sets the measurement unit and the display mode.

dEC = linear measurement display (decimal)

FrEE = display with conversion factor

dG1 = angular display (-∞..-0,1°..0,0°..+0,1°..+∞)

dG2 = angular display (..359,9°..0,0°..359,9°..0,0°..)

ldEC = inch display mode

lfrct = fractional inch mode (eg. 12.31.64 = 12" ³¹/₆₄)

* = save, P = next parameter, P for 3 s. = exit

COn only with Unit = FrEE, dG1, dG2

Allows to set a free conversion factor to display non-metric units or angles.

Valeu range:

FrEE = 0,00001 - **1,00000**

dG1, dG2 = 0,00001 - 9,99999

Example 1:

Want to display a 90° angle (from 0° to 90°) with 0,1° resolution on a round table with 785,4 mm circumference.

The measurement length on 360° is 785,4 mm, though on 90.0° it is $785,4 / 4 = 196.35$.

COn = $900 : 19635 = 0,045836$

Example 2:

Want to display angles on a magnetic ring with diameter 114,5 mm.

The circumference is $114.5 * 3.14 = 359.53$ mm

COn = $3600 : 35953 = 0,10013$

* = save, **P** = next parameter, **P** for 3 s. = exit

rES Resolution

(only with Unit = dEC, FrEE, dG1, dG2, IdEC)

Sets the resolution to be displayed.

Unit = dEC, FrEE, dG1, dG2 = 0.001, 0.005, **0.01**, 0.05, 0.1, 0.5, 1

Unit = IdEC = 0.0001, 0.0005, **0.001**, 0.005, 0.01, 0.05, 0.1

* = save, **P** = next parameter, **P** for 3 s. = exit

dIr Counting direction [uP, dn]

uP = up (standard direction)

dn = down (inverted direction)

* = save, **P** = next parameter, **P** for 3 s. = exit

6.3.3 Additional function of MENU 1

F_mml mm/inch function [yES, no]

Enables the mm/inch function (by pushing ← key)

yES = enabled

no = disabled

* = save, **P** = next parameter, **P** for 3 s. = exit

F_rEL Incremental measurement function [yES, no]

Enables incremental measurement function (by pushing **P** and * keys).

yES = enabled

no = disabled

* = save, **P** = next parameter, **P** for 3 s. = exit

F_rSt Datum function [yES, no]

Enables datum function (by pushing * key).

yES = enabled

no = disabled

* = save, **P** = next parameter, **P** for 3 s. = exit

F_rEF Datum modification function [yES, no]

Enables reference modification function (by pushing **P** and ↑ key).

yES = enabled

no = disabled

* = save, **P** = next parameter, **P** for 3 s. = exit

F_oFS Offset modification function [yES, no]

Enables offset modification function (by pushing **P** and ← keys).

yES = enabled

no = disabled

* = save, **P** = next parameter, **P** for 3 s. = exit

rEF Datum value [-999999, 999999]

Absolute reference value for the measuring system. This value is displayed by pushing * key for 3 s. (displayed value includes previously set offset values).

* = save, **P** = next parameter, **P** for 3 s. = exit

OFS1 Offset1 value [-999999, 999999]

First offset value (e.g. tool correction). This value is added to actual value (see 6.2.3.)

* = save, **P** = next parameter, **P** for 3 s. = exit

OFS2 Offset2 value [-999999, 999999]
 Second Offset value. This value is added to actual value and OFS1.

* = save, **P** = next parameter, **P** for 3 s. = exit

OFS3 Offset3 value [-999999, 999999]
 Third Offset value. This value is added to actual value, OFS1 and OFS2.

* = save, **P** = next parameter, **P** for 3 s. = exit

When the setup is completed the display shows "rESEt"

Push * key twice to reset the display and quit the setup. "donE" will be displayed.

Push **P** key quit the setup without resetting the display. "no rSt" will be displayed.

6.3.4 Parameter list MENU 2

Ad xx Device address [01, 31]
 Setting of device address (only if ordered with serial interface (option I1).

For setting use ← and ↑ keys.

* = save, **P** = next parameter

H_cntr Hour meter (1/10 h)
 Elapsed time indication (display connected to battery). Resolution is 1/10 hour (6 minutes).

* = save, **P** = next parameter

7 - RS232 serial interface (option I1)

If the display is provided with RS232 serial interface, the following commands can be used.

7.1 RS232 parameters

9600 Baud, 8Bit, no Parity, 1 Stop bit, Xon/Xoff

7.2 Serial commands

Serial commands must have the following structure:

| **ADCMND=X**

where:

|: PC keyboard symbol

AD: device address (00 to 31) 2 digit

CMND: command (see command list)

X: value range (see command list)

Upon receipt of a wrong command the display will answer with the same command + ? and checksum (e.g. sent command: |02azs → answer |02azs?EF)
 Any common terminal program can be used for communication with LD140 (e.g. Hyperterminal).
 Commands will be send after confirmation by ENTER key (carriage return).

Answers are structured as follows:

ADCMND:XXXXXXXXCK

where:

AD: device address

CMND: command

XXXXXXXX: value

CHKS: checksum

The checksum is equal to the least significant byte of the summing the hex values of all characters transmitted.

Example:

The displayed position is 8,29. The position of device with address 01 is read by means of the |01TPOS command.

The answer is: 01TPOS:+000008299F

The sum of hex values of all characters is the following:

30+31+54+50+4F+53+3A+2B+30+30+30+30+30+38+32+39 = 39F

The least significant byte of 39F is **9F** which is the checksum.

7.2.1 Command list

(below the device address is indicated with **AD**)

Zeroing of device address

|00RSET

Address of all connected devices is set to zero (0).

Device address [1, 31]

|00INIT=X

Sets address of all connected devices to value X.

Display device address

|00DADR

Displays device address until **P** key is pushed.

Change device address [1, 31]

|ADRADR=X

Changes actual device address AD to X.

Answer : ADTADR:+XCHKS (CHKS is checksum and X is value).

Read actual position

|ADTPOS

Reads actual position of device **AD** (resolution of value is 0,01mm or 0,001 inch depending on settings).

Change counting direction [0, 1]

|ADRDIR=X

Sets counting direction.

X=0 → **uP** = standard direction

X=1 → **dn** = inverted direction

Answer: ADTDIR:+0000000XCHKS

Read counting direction

|ADTDIR

Reads the actual counting direction.

X=0→**uP** , **X=1**→**dn**

Answer: ADTDIR:+0000000XCHKS

Measurement unit [0, 5]

|ADRUNI=X

Sets the measurement unit and display mode.

X=0→ **dEC** = decimal mode

X=1→ **FrEE** = display with conversion factor

X=2→ **dG1** = angular ($-\infty..-0,1^{\circ}..0,0^{\circ}..+0,1^{\circ}..\infty$)

X=3→ **dG2** = angular ($..359,9^{\circ}..0,0^{\circ}..359,9^{\circ}..0,0^{\circ}..$)

X=4→ **IdEc** = decimal inch display mode

X=5→ **lfrc** = fractional (es. $12.31.64 = 12''^{31/64}$)

Answer: ADTUNI:+0000000XCHKS

Read measurement unit

|ADTUNI

Reads the status of measurement unit.

Answer: ADTUNI:+0000000XCHKS

Resolution [1, 5, 10, 50, 100, 500, 1000]

|ADRRES=X

Sets linear resolution in mm or *inch*.

X=1→ 0.001/0.0001, **X=5**→ 0.005/0.0005,

X=10→ 0.01/0.001, **X=50**→ 0.05/0.005,

X=100→ 0.1/0.01, **X=500**→ 0.5/0.05,

X=1000→ 1/0.1

Answer: ADTRES:+XCHKS

Read resolution

|ADTRES

Reads value of actual resolution (see values above).

Answer: ADTRES:+XCHKS

Free conversion factor COn

[with FrEE 0,00001 - 1,00000 / with dG1, dG2 0,00001 - 9,99999]

|ADRFRE=X

Sets free conversion factor COn (see chapter 6.3.1).

Answer: ADTFCO:+XCHKS

Read COn conversion factor

|ADTFCO

Reads value of actual COn factor.

Answer: ADTFCO:+00X.XXXXCHKS

Display mm/inch display mode [0, 1]

|ADRMMI=X

Changes display mode from mm to inch.

X=0→ mm, **X=1**→inch

Answer: ADTMMI:+0000000XCHKS

Read mm/inch display mode

|ADTMMI

Reads status of mm/inch display mode.

X=0→ mm, X=1→ inch

Answer: ADTMMI:+0000000XCHKS

Incremental measurement function [0, 1]

|ADRRLA=X

Enables incremental measurement function (key combination **P** and *****).

X=0→ off, X=1→ on

Answer: ADTRAE:+0000000XCHKS

Read incremental measurement

|ADTRAE

Reads status of incremental measurement function.

X=0→ off, X=1→ on

Answer: ADTRAE:+0000000XCHKS

Incremental measurement [0, 1]

|ADRRLA=X

Sets from absolute display mode to incremental (relative).

X=0→ off, X=1→ on

Answer: ADTRAE:+0000000XCHKS

Read incremental measurement

|ADTRLA

Reads status of absolute/incremental display mode.

X=0→ off, X=1→ on

Answer: ADTRLA:+0000000XCHKS

Datum function [0, 1]

|ADRRSE=X

Enables Datum function (by pushing ***** key).

X=0→ off, X=1→ on

Answer: ADTRSE:+0000000XCHKS

Read Datum function

|ADTRSE

Reads status of Datum function.

X=0→ off, X=1→ on

Answer: ADTRSE:+0000000XCHKS

Datum value modification [0, 1]

|ADRRFE=X

Enables Datum value modification (by key combination **P** and **↑**).

X=0→ off, X=1→ on

Answer: ADTRFE:+0000000XCHKS

Read Datum value modification

|ADTRFE

Reads status of Datum value modification.

X=0→ off, X=1→ on

Answer: ADTRFE:+0000000XCHKS

Offset function [0, 1]

|ADROFE=X

Enables Offset function (by key combination **P** and **←**).

X=0→ off, X=1→ on

Answer: ADTOFE:+0000000XCHKS

Read Offset function

|ADTOFE

Reads status of Offset function.

X=0→ off, X=1→ on

Answer: ADTOFE:+0000000XCHKS

Datum value [-999999, 999999]

|ADRREF=X

Absolute Reference value for the measurement system. (the value has resolution 0,01mm or 0,001 inch depending on the display settings).

Answer: ADRREF:XCHKS

Read Datum value

|ADTREF

Reads actual Datum value.

Answer: ADTREF:XCHKS

Offset1 value [-999999, 999999]

|ADROF1=X

Sets Offset1 (OFS1) value (the value has resolution 0,01).

Answer: ADROF1:XCHKS

Read Offset1 value

|ADTOF1

Reads actual Offset1 value.

Answer: ADTOF1:XCHKS

Offset2 value [-999999, 999999]

|ADROF2=X

Sets Offset2 (OFS2) value (the value has resolution 0,01).

Answer: ADROF2:XCHKS

Read Offset2 value

|ADTOF2

Reads actual Offset2 value.

Answer: ADTOF2:XCHKS

Offset3 value [-999999, 999999]

|ADROF3=X

Sets Offset3 (OFS3) value (the value has resolution 0,01).

Answer: ADROF3:XCHKS

Read Offset3 value

|ADTOF3

Reads actual Offset3 value.

Answer: ADTOF3:XCHKS

8 - Cut-out

8.1 LD140 and LD142

Provide a 94 x 68 mm (w x h) cut-out.

8.2 LD141

Check details on product catalogue.

Rev.	Man.Vers.	Description
0	1.0	1 [^] issue
	4.1	SW + Manual update
3	4.2	Chap.5 correction
4	4.3	Reset function correction (chap. 6.2.1)

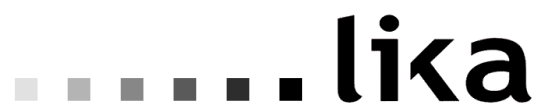

LIKA Electronic

Via S. Lorenzo, 25 - 36010 Carrè (VI) - Italy

Tel. +39 0445 382814

Fax +39 0445 382797

Italy: eMail info@lika.it - www.lika.it

World: eMail info@lika.biz - www.lika.biz