

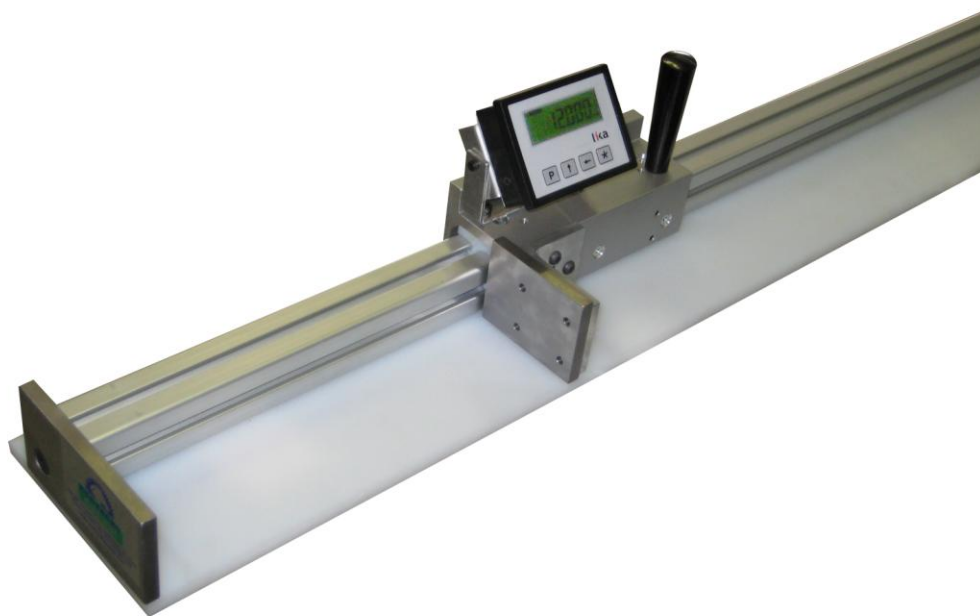

# **MMP**

## **Digital Length Measuring Gauge**



*\*shown with optional measuring surface*

---

# **INSTRUCTION MANUAL**

---

Hymark Ltd. – 427 Bark cove– Owensboro, KY 42303  
(270) 683-3500 – Fax (270) 683-2500  
[www.kentuckygauge.com](http://www.kentuckygauge.com)



# Table of contents

<b>1. Product Description</b>	<b>4</b>
1.1 <i>Intended use</i>	4
<b>2. Basic Safety Hints</b>	<b>5</b>
2.1 <i>Notice hints inside manual</i>	5
2.2 <i>Owner obligations</i>	5
2.3 <i>Operator obligations</i>	5
2.4 <i>Intended use</i>	5
<b>3. Maintenance Requirements</b>	<b>7</b>
3.1 <i>Lubricants and Detergents</i>	7
3.2 <i>Maintenance Schedule</i>	7
3.3 <i>Cleaning the Guide Rail</i>	7
3.4 <i>Cleaning the Magnetic Tape</i>	7
3.5 <i>Cleaning the Carriage</i>	8
3.6 <i>Cleaning the Contact Plates</i>	8
<b>4. DRO Operation</b>	<b>9</b>
4.1 <i>Setting the Datum</i>	9
4.2 <i>Entering/Changing the Datum Value</i>	9
4.3 <i>Setting the Display Mode (Inch-to-metric)</i>	9
4.4 <i>Changing from Absolute to Incremental Measuring</i>	9
<b>5. DRO Parameter Mode</b>	<b>10</b>
5.1 <i>Entering Parameter Mode</i>	10
5.2 <i>Editing Paramters</i>	10
5.3 <i>How to exit Paramter Mode</i>	10
5.4 <i>Parameter List</i>	10
<b>6. DRO Specs</b>	<b>13</b>
6.1 <i>Dimensional Drawing</i>	13
6.2 <i>Technical Data</i>	13
6.3 <i>Integrated Sensor Specs</i>	13
<b>7. Warranty</b>	<b>14</b>

# 1. Product Description

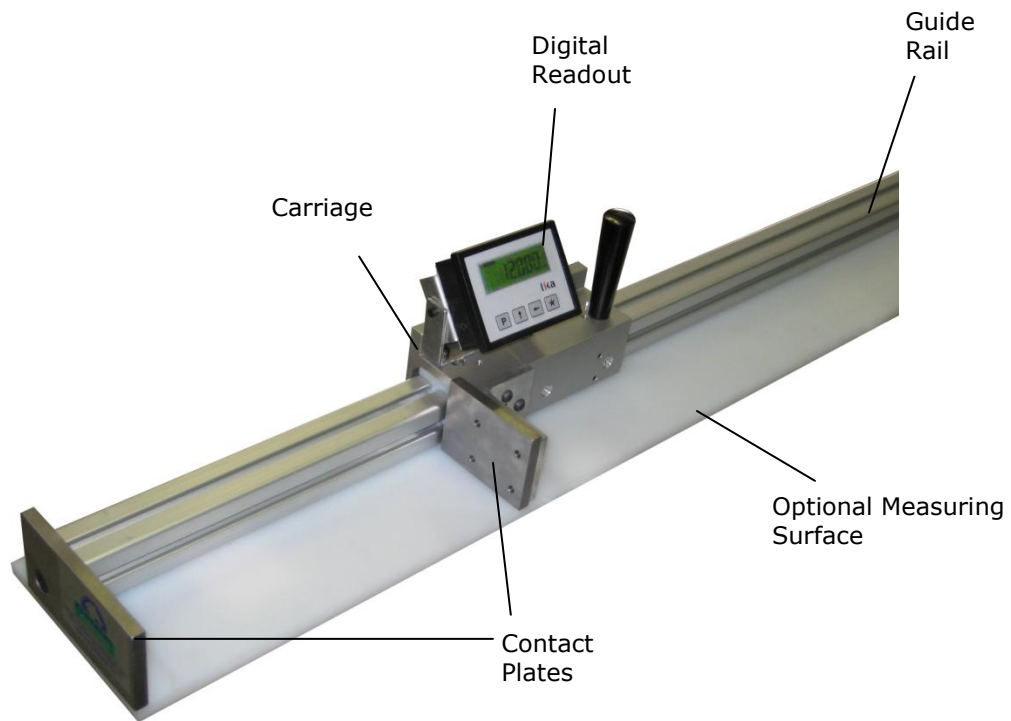

## 1.1 Intended Use

The only acceptable use for the MMP is as a length measuring gauge system. Never place any material on the measuring surface except the piece to be measured. Any other use is not intended and is a misuse of the gauging system.

## **2. Basic safety hints**

### **2.1 Read and follow all hints inside the Instruction Manual**

Basic requirements for the correct use of the gauging system or the machine are the knowledge of the basic safety hints and the safety precautions.  
This instruction manual contains the most important safety hints.

This instruction manual, especially the safety hints and precautions must be followed by every person working with this gauge or machine.  
Also follow all general plant safety rules and precautions not mentioned in this manual.

### **2.2 Owner obligations**

The owner agrees to only allow the gauge or the machine to be used by qualified and trained persons who

- Have been instructed in the general safety rules and precautions
- Have been instructed in the correct use of the gauge and machine
- Have read and understood the safety chapters and caution hints of this instruction manual.

### **2.3 Operator obligations**

All persons working with this gauge and machine agree before starting to work

- To follow the general safety rules
- To read and understand the safety chapters and caution hints of this instruction manual.

### **2.4 Intended use**

The only acceptable use for this gauge is as a length gauging system. Any other use is not intended and is a misuse of the gauging system.  
Hymark is not liable for any damages resulting from misuse.  
Intended use also means:

- Following all safety hints and precautions mentioned in this manual
- Following the maintenance and inspection procedures as mentioned in this manual.

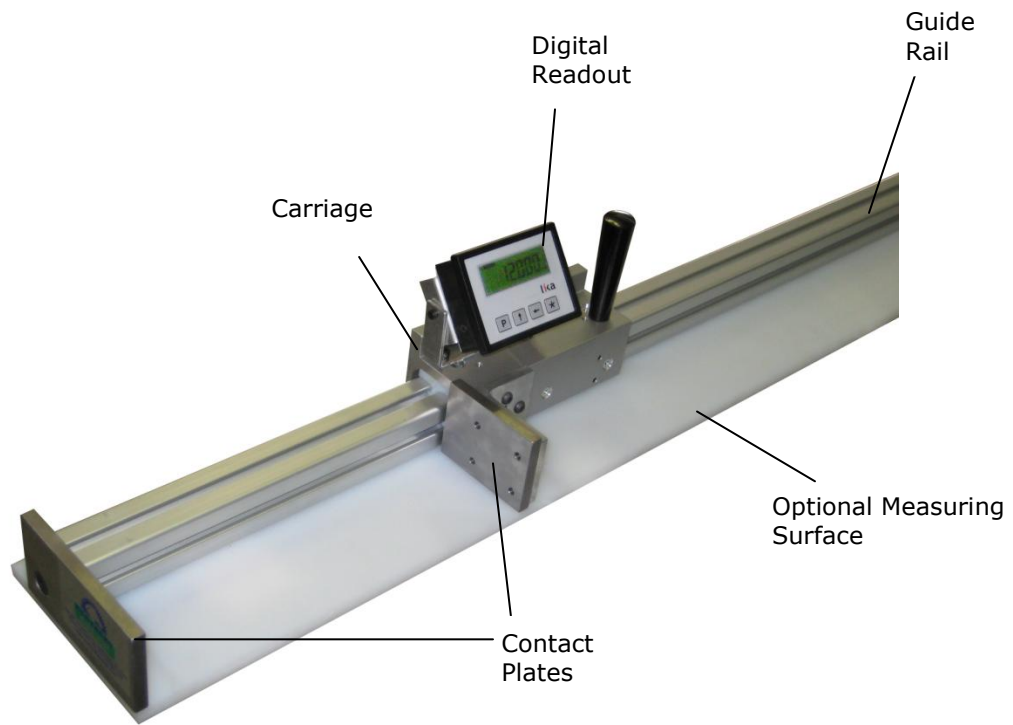

**Note: LCD displays is powered by 1 'C' battery and will not power off. Battery will need to be replaced approximately every 12 months.**

### 3 Maintenance Requirements

Maintenance jobs as described in this chapter may only be done by authorized and trained personnel.

\*\*Prior to any maintenance of the Kentucky Gauge or accessories, please ensure the machine is not in operation and corresponding equipment is in "off" position.

#### 3.1 Lubricants and Detergents

##### Detergent

- ☞ Use commercially available detergents.
- ☞ Don't use any acids or alkaline solutions
- ☞ Don't use any high pressure water jet cleaners

#### 3.2 Maintenance Schedule

See chapter	Device	Cleaning	Lubricate	In addition	Frequency
3.3	Guide Rail	X	--	--	daily
3.4	Magnetic tape mounted to bottom side of aluminum extrusion	X	--	--	daily
3.5	Carriage	X	--	--	daily
3.6	Contact Plates	X	X	--	daily

Legend: X - has to be done -- Nothing to do

#### 3.3 Cleaning the Guide Rail

- ☞ Remove chips, grease and any items on the conveyor/table that would be deemed in the pathway of, or causing an unwanted obstruction of, the carriage/gang stop. This should be done several times per day if the machine is in heavy use.

#### 3.4 Cleaning the Magnetic Tape

- ☞ Remove chips and grease on the magnetic tape and between reader head and tape. This should be checked daily to ensure there is no development of debris or obstruction. If heavy chip or debris accumulation occurs, increase frequency to accommodate suitable maintenance measures.
- ☞ The sensor to scale gap should be within the range of 0.1mm to 1.0mm

### **3.5 Cleaning the carriage**

- ☞ Remove chips, grease and any items on the conveyor/table/measuring surface that would be deemed in the pathway of, or causing an unwanted obstruction of, the carriage/contact plate. This should be done several times per day if the machine is in heavy use.
- ☞ Ensure that the hardware connecting the contact plates to the carriage is secured. This may be checked on a quarterly basis or implemented in line with the standard preventative maintenance schedules for the other equipment in the facility.

### **3.6 Cleaning the contact plates**

- ☞ Wipe down plates and remove any dirt, grime, or moisture.
- ☞ Apply a liberal coat of oil (3-in-1 oil or similar) to every exposed surface of the contact plates to prevent corrosion.



## 4 DRO Operation

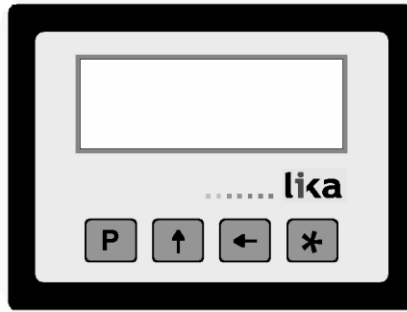

<b>P</b>	:	Program (programming/change parameters)
<b>↑</b>	:	UP (increase value of selected digit)
<b>←</b>	:	Shift left (select digit)
<b>*</b>	:	Save (save data)

### 4.1 Setting Datum (Referencing the system)

By setting the datum or referencing the system, the operator is setting up the system so that the distance from the moving contact plate to the stationary contact plate is correctly displayed in the digital readout.

**NOTE:** Your datum value needs to be set before performing this function.  
See "4.2 Entering / changing datum value"

1. Move the stop to a known location using a standard or other suitable method.
2. Press the \* button for 3 seconds.
3. The display will show "rESEt"
4. Press the \* button again to show the current position flashing. Note: at this point the referencing can be cancelled by pressing "P"
5. Press the \* button again to confirm the reference reset by displaying "done" momentarily. This will set the display to the pre-entered datum value.

### 4.2 Entering / changing datum value

Push **P** and **↑** buttons together to display datum value "rEF". Use **←** and **↑** keys to change value and save with \* button.

This feature is only enabled if "F\_rEF" parameter is set to "on" (see chapter 5).

### 4.3 Setting the Display Mode (Toggle from inch to metric)

The display can be easily changed to display inch or metric values by pressing the **←** button for 3 seconds. Note: inch mode with 3 decimals or fraction display must be selected in parameter **Inch\_F** (see chapter 5).

### 4.4 Changing from Absolute Measuring to Incremental Measuring

The display can be changed from absolute measuring (unit displays actual distance from saw blade) to incremental or relative measuring (unit displays distance from last position).

Pressing the **P** and \* buttons together toggles these modes.

Note: INC is shown in the display when the unit is running in incremental mode.

Note: Setting the display to zero in incremental mode is not affecting the real absolute value

## 5. DRO Parameter Mode

### 5.1 Entering Parameter Mode

Press **P** button for 3 seconds to enter setup mode. "SETUP" will be shown in the display.  
Press **↑** button to enter Menu 1 (parameter mode)

### 5.2 Editing Parameters

Press **P** button to select next Parameter and Parameter setting.  
Press **\*** button to save entered values

### 5.3 How to exit Parameter Mode

Press **P** button until you reach final parameter **rESet**.  
Now press **P** button twice to return to operating mode.

### 5.4 Parameter List

Parameter description	Factory Setting	User Setting
<b>dG_Ln Degrees/Linear (dG, dG2, Lin)</b> Angular or linear display mode. <b>Lin</b> = ..0,0..0,1..0,2..0,3 mm <b>dG1</b> = angles ..-0,1°..0,0°..+0,1°..+359,9°..0,0° <b>dG2</b> = angles ..359,9°..0,0°..0,1°..359,9°..0,0° * = save, P = next parameter Note: when selecting <b>dG1</b> or <b>dG2</b> the next available parameter will be <b>FrEE</b> not <b>rES</b> .	Lin	_____
<b>rES Resolution (10, 50, 100, 1000, FrEE)</b> Linear resolution value in microns. 10 = 0.01mm 50 = 0.05 mm 100 = 0.1 mm 1000 = 1 mm <b>FrEE</b> allows to enter a resolution factor e.g. for angular displays (basis of calculation is max. resolution 0.01 mm). * = save, P = next parameter	10	_____
<b>FrEE Ln mode (0,0001, 1,0000)</b> <b>FrEE dG mode (0,0001, 9,9999)</b> e.g. angle display with range from 0° to 90° and 0,1° resolution on a rotating table with circumference of 785,4 mm. Total working range is 785,4 mm : 4 = 196.35 mm. FrEE = 900 : 19635 = 0,045836 * = save, P = next parameter	-	_____

<b>Parameter description</b>	<b>Factory Setting</b>	<b>User Setting</b>
<p><b>Measurement unit (both, dEc, Inch)</b>  Sets the display mode.  both = mm/inch can be selected  (see chapter 4.6)  &lt;jump to parameters dd_n, Inch_F&gt;  dEc = mm display mode  &lt;jump to parameter dd_n&gt;  Inch = inch display mode  &lt;jump to parameter Inch_F&gt;  * = save, P = next parameter</p>	<b>both</b>	_____
<p><b>dd_n Decimal digit number (0, 1, 2)</b>  Sets the decimal point position.  0 = no decimal point  1 = one decimal (e.g. 1,0)  2 = two decimals (e.g. 1,00)  * = save, P = next parameter</p>	-	_____
<p><b>Inch_F Inch function (Inch1, Inch2)</b>  Sets the inch display mode.  Inch1 = inch with 3 decimals (e.g. 1234.567)  Inch2 = fraction mode (e.g. 12.31.64 = 12" <sup>31</sup>/<sub>64</sub>)  * = save, P = next parameter</p>	<b>Inch2</b>	_____
<p><b>dIr Counting direction (uP, dn)</b>  uP = up (standard direction)  dn = down (inverted direction)  * = save, P = next parameter</p>	<b>uP</b>	_____
<p><b>F_rEL Incremental mode activation (on, oFF)</b>  Enables incremental mode by pushing P and * buttons together  on = activated  oFF = deactivated  * = save, P = next parameter</p>	<b>on</b>	_____
<p><b>F_rSt Datuming mode (on, oFF)</b>  Enables datum function by pushing * button  on = activated  oFF = deactivated  * = save, P = next parameter</p>	<b>on</b>	_____
<p><b>F_rEF Datum modification function (on, oFF)</b>  Enables "change reference value" mode by pushing P and ↑ buttons together  on = activated  oFF = deactivated  * = save, P = next parameter</p>	<b>on</b>	_____

<b>Parameter description</b>	<b>Factory Setting</b>	<b>User Setting</b>
<p><b>F_oFS Offset mode (on, oFF)</b>            Enables offset modification function by pushing P and ← buttons together            on = activated            oFF = deactivated            * = save, P = next parameter</p>	<b>oFF</b>	_____
<p><b>rEF Datum value (-999999, 999999)</b>            Absolute reference value for encoder.            This value is displayed by pushing the * button for 3 seconds.            Note: displayed value = actual value + offset values (if entered).            * = save, P = next parameter</p>	<b>0</b>	_____
<p><b>OFSt1 Offset1 value (-999999, 999999)</b>            First offset value (e.g. tool offset). This value Will be added to actual value            * = save, P = next parameter</p>	<b>0</b>	_____
<p><b>OFSt2 Offset2 value (-999999, 999999)</b>            Second Offset value. This value will be added to actual value + OFSt1.            * = save, P = next parameter</p>	<b>0</b>	_____
<p><b>OFSt3 Offset3 value (-999999, 999999)</b>            Third Offset value. This value will be added to actual value + OFST1 + OFST2.            * = save, P = next parameter</p>	<b>0</b>	_____
<p><b>rESEt</b>            Press <b>P</b> button to reset display and exit menu.            Display will show rEF+OFSt1 value.            Push <b>P</b> button again to exit Setup mode and to return to operating mode</p>		

## 6. DRO Specs

### 6.1 DRO Dimensional Drawing (mm)

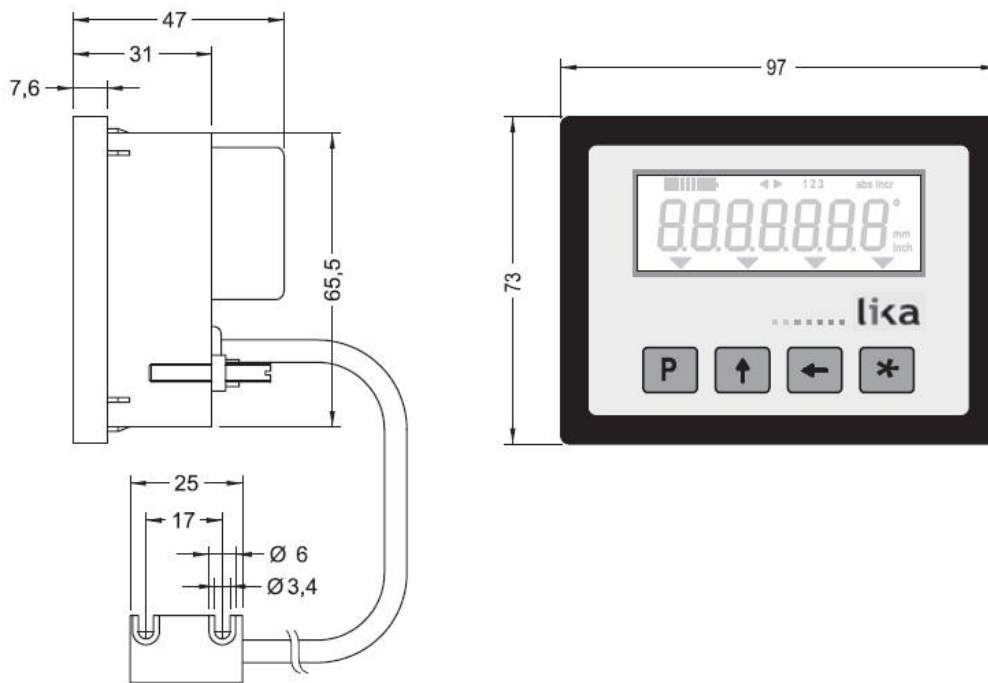

### 6.2 Technical Data

LCD display	:	7 digits plus sign symbol , 11 mm high
Battery	:	1 commonly available "C" battery , 1.5V
Consumption	:	700 $\mu$ A
Operating temperature	:	-20°C to 80°C (-4°F to 176°F)
Operating Speed	:	max. 2.5m/sec (100in/sec)
Resolution	:	0.001in
Housing	:	Black metal for panel mounting
Dimensions (mm)	:	96w x 73h x 47d
Cut Out (mm)	:	91.5w x 67.5h
Protection Class	:	IP60 front, IP40 back

### 6.3 Integrated Sensor Specifications

<u>Technical Data</u>	
Cable Length	: 0.2 m
Protection	: IP67
Operating Temperature	: 5°C - 50°C (41°F-122°F)
Orientation	: Any
Bend Radius	: min 60mm (2.5in)
Gap Tape/Sensor	: max 1mm (0.04in)

## 9 Warranty

Hymark Ltd Co (henceforth Hymark), warrants this product for a period of twenty-four (24) months from the date of shipment. During the warranty period, under authorized return component parts to Hymark freight prepaid, the company will repair, or at its option, replace any part found to be defective in material or workmanship, without charge to the owner for parts, service labor, or associated customary shipping costs.

This same protection will extend to any subsequent owner during the warranty period. It does not apply to damage caused by accident, misuse, fire, flood or acts of God, or from failure to properly install, operate, or maintain the product in accordance with the printed instructions provided.

**This warranty is in lieu of any other warranties, expressed or implied, including merchantability or fitness for a particular purpose, which are expressly included. The owner agrees that Hymark's liability with respect to this product shall be set forth in this warranty, and incidental or consequential damages are expressly excluded.**

Any questions or inquiries should be directed to our factory technical department at 270-683-3500 ext. 114

Hymark Ltd. – 427 Bark cove– Owensboro, KY 42303  
(270) 683-3500 – Fax (270) 683-2500  
[www.kentuckygauge.com](http://www.kentuckygauge.com)

## User manual

### LD140-M7 + SM25

### LD141-M7-R-...

### LD142-M7-R-...

#### Description

This manual describes the LD14x battery display series and the sensors of the SM25 series. The purpose of this system is to display linear or angular displacements on industrial machines and on automation systems. The measurement system includes a battery powered LCD display, magnetic tape and a magnetic sensor. As the sensor is moved along the magnetic tape, it detects the displacement which is shown on the display. The flexibility of the tape allows it to be used for both linear and angular applications.

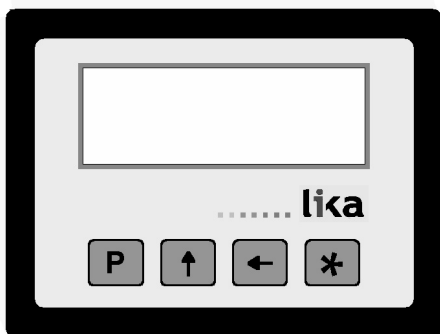

#### Chapters

- 1 Safety summary
- 2 Identification
- 3 Installation
- 4 Mounting recommendations
- 5 Electrical connections
- 6 Setup
- 7 RS232 serial interface (only with option I1)
- 8 Dimensional drawings and cut-out

#### 1 - Safety summary

We strongly recommend carefully reading this user manual and following the installation guidelines:

- Sensor head should be installed as close as possible to the display.

- Avoid running the sensor cable near high voltage power cables (e.g. drive cables).
- Avoid mounting sensor head near capacitive or inductive noise sources such as relays, motors, and switching power supplies.

Connect according to chapter 5.

#### 2 - Identification

The display and sensor can be identified by the label's data (ordering code, serial number). This information is listed in the delivery document. For technical features please refer to the product catalogue.

#### 3 - Installation

Install the product according to the protection level provided.

Protect the system against knocks, friction, solvents, temperatures under  $-0^{\circ}\text{C}$  ( $32^{\circ}\text{F}$ ) and over  $+60^{\circ}\text{C}$  ( $+140^{\circ}\text{F}$ ).

Be sure that the system is mounted where hard or sharp objects (e.g. metal chips) do not come into contact with the magnetic scale and the bottom of the sensor head. If these conditions cannot be avoided provide a wiper or pressurized air.

#### 4 - Mounting recommendations

##### 4.1 Display

Push the display into the cut-out without panel clips.

Install panel clips on the display's housing and screw until fixed and stable.

Power supply by 1.5V commercial battery type C (or AM2 / BABY / LR14 / MN1400 / SP/HP11).

##### 4.2 Magnetic tape

See manual supplied with the magnetic tape.

##### 4.3 Sensor mounting

###### 4.3.1 Sensor SM25-R (rectangular)

Sensor can be fixed by means of two M3 screws over the buttonholes. Make sure that the gap between sensor and tape is in respect with (fig. 1) along the total measuring length. Avoid contact between the parts. You can check planarity and parallelism between sensor and magnetic tape using a feeler gauge.

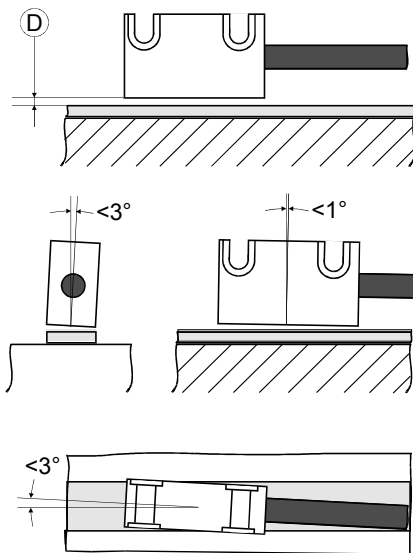

figure 1

D = 0,1 mm - 1,0 mm

**4.3.2 Sensor SM25-C (circular)**

The sensor can be fixed in a corresponding mounting hole by means of the two nuts. Make sure that the gap between sensor and tape is in respect with (fig. 2) along the total measuring length. **Observe the correct alignment of the marker on the tape.** Avoid contact between the parts. You can check planarity and parallelism between sensor and magnetic tape using a feeler gauge.

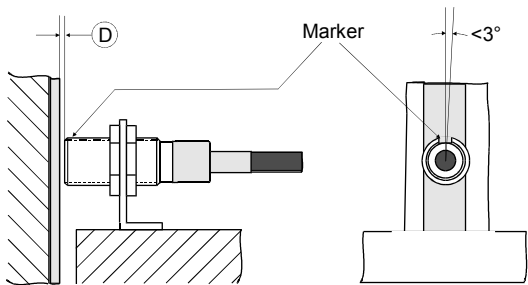

figure 2

D = 0,1 mm - 1,0 mm

**5 - Electrical connections**

**5.1 SM25 sensor (only LD140)**

Plug in the sensor's Mini-DIN connector (circular) on backside of the display.

**5.2 RS232 serial interface (only with option I1)**

Connect PC to LD14x with NULL MODEM COMPUTER AT CROSS OVER cable (9 pin female - 9 pin female) available in commerce.

Electrical cable connection:

Pin PC	Function	Pin LD14x
1		
2	Rx	3
3	Tx	2
4	DTR	6 *
5	GND	5
6	DSR	
7	RTS	8 *
8	CTS	
9		

\* Power supply has to be provided to RS232 interface to avoid battery consumption. If not connect to the PC provide power supply (8-15Vdc) to pin 6 or 8. External supply isn't needed if using a Modem computer cable!



## 6 - Setup

### 6.1 Key's function

- ↑ : UP (select value)
- ← : Shift links (select digit)
- \* : Save (save data)
- P : Program (programming/change parameter)

### 6.2 Key combinations / Quick functions

#### 6.2.1 Set datum (reference)

Push \* key for 3 sec. to access reset function ("rESet" will be displayed).

Push P key to exit function (no reset).

Push \* key twice to confirm datum value ("donE" will be displayed).

Display value = rEF + OFS1 + OFSx (where OFSx is the actually set Offset value).

This function is enabled only if "F\_rSt" parameter is set "yES".

#### 6.2.2 Incremental measurement

Push P and \* key simultaneously to switch from absolute measurement to incremental.

Zero setting in incremental modes (see 6.2.1) does not change absolute value in the background.

The function is enabled only if "F\_rEL" parameter is set "yES".

#### 6.2.3 Mm/inch display modes

Mm/inch display modus can be changed by pushing ← key for 3 s. The function is enabled only if "F\_mml" parameter is set "yES".

#### 6.2.4 Offset value modification

Push P and ← keys simultaneously to display 1. Offset value (OFS1). Use ← and ↑ keys to change value and save with \* key. Further Offset values OFS2 and OFS3 can be changed only in setup menu. Offset function is enable if "F\_oFS" parameter is set "yES".

← key allows to scroll OFS1, OFS2 and OFS3 values.

OFS1 = actual value + OFS1 + rEF

OFS2 = actual value + OFS1 + OFS2 + rEF

OFS3 = actual value + OFS1 + OFS3 + rEF

#### 6.2.4.1 Fractional offset display

The fractional inch display mode allows to set offset values (OFS) in the following way:

- 1<sup>st</sup> digit blinking → increases 1/64" pushing ↑ key.
- 2<sup>nd</sup> digit blinking → increases 1/32" pushing ↑ key.
- 3<sup>rd</sup> digit blinking → increases 1/16" pushing ↑ key.
- 4<sup>th</sup> digit blinking → increases 1/8" pushing ↑ key.
- 5<sup>th</sup> digit blinking → increases 1" pushing ↑ key.
- 6<sup>th</sup> digit blinking → increases 10" pushing ↑ key.

#### 6.2.5 Datum modification

Push simultaneously P and ↑ keys to display datum value rEF. Use ← and ↑ keys to change value and save with \* key.

This function is enabled only if "F\_rEF" parameter is set "yES".

### 6.3 Setup / Parameter setting

Push P key for 3 s to enter setup and "SEtUP" is displayed.

Push ↑ key to enter **MENU 1** (parameters)

Push \* key to enter **MENU 2** (RS232 serial interface)

Push P key to access the next Parameter and Parameter setting.

Push P key for 3 s to exit the setup at any point.

#### 6.3.1 Default parameters (factory settings)

All default values are written in **BOLD** characters.

The display can be reset to default parameters with the following procedure:

- take out battery and wait for 10 s.
- while putting in the battery push \* key ("dEFFPar" is displayed)

#### 6.3.2 Parameter list **MENUE 1**

**Unit** Measurement unit [dEC, FrEE, dG1, dG2, ldEC, lfrct]

Sets the measurement unit and the display mode.

**dEC** = linear measurement display (decimal)

FrEE = display with conversion factor

dG1 = angular display (-∞..-0,1°..0,0°..+0,1°..+∞)

dG2 = angular display (..359,9°..0,0°..359,9°..0,0°..)

ldEC = inch display mode

lfrct = fractional inch mode (eg. 12.31.64 = 12" <sup>31</sup>/<sub>64</sub>)

\* = save, P = next parameter, P for 3 s. = exit

**COn** only with Unit = FrEE, dG1, dG2

Allows to set a free conversion factor to display non-metric units or angles.

Valeu range:

FrEE = 0,00001 - **1,00000**

dG1, dG2 = 0,00001 - 9,99999

### Example 1:

Want to display a 90° angle (from 0° to 90°) with 0,1° resolution on a round table with 785,4 mm circumference.

The measurement length on 360° is 785,4 mm, though on 90.0° it is  $785,4 / 4 = 196.35$ .

**COn** =  $900 : 19635 = 0,045836$

### Example 2:

Want to display angles on a magnetic ring with diameter 114,5 mm.

The circumference is  $114.5 * 3.14 = 359.53$  mm

**COn** =  $3600 : 35953 = 0,10013$

\* = save, **P** = next parameter, **P** for 3 s. = exit

**rES** Resolution

(only with Unit = dEC, FrEE, dG1, dG2, IdEC)

Sets the resolution to be displayed.

Unit = dEC, FrEE, dG1, dG2 = 0.001, 0.005, **0.01**, 0.05, 0.1, 0.5, 1

Unit = IdEC = 0.0001, 0.0005, **0.001**, 0.005, 0.01, 0.05, 0.1

\* = save, **P** = next parameter, **P** for 3 s. = exit

**dIr** Counting direction [uP, dn]

**uP** = up (standard direction)

**dn** = down (inverted direction)

\* = save, **P** = next parameter, **P** for 3 s. = exit

### 6.3.3 Additional function of MENU 1

**F\_mml** mm/inch function [yES, no]

Enables the mm/inch function (by pushing ← key)

yES = enabled

**no** = disabled

\* = save, **P** = next parameter, **P** for 3 s. = exit

**F\_rEL** Incremental measurement function [yES, no]

Enables incremental measurement function (by pushing **P** and \* keys).

yES = enabled

**no** = disabled

\* = save, **P** = next parameter, **P** for 3 s. = exit

**F\_rSt** Datum function [yES, no]

Enables datum function (by pushing \* key).

yES = enabled

**no** = disabled

\* = save, **P** = next parameter, **P** for 3 s. = exit

**F\_rEF** Datum modification function [yES, no]

Enables reference modification function (by pushing **P** and ↑ key).

yES = enabled

**no** = disabled

\* = save, **P** = next parameter, **P** for 3 s. = exit

**F\_oFS** Offset modification function [yES, no]

Enables offset modification function (by pushing **P** and ← keys).

yES = enabled

**no** = disabled

\* = save, **P** = next parameter, **P** for 3 s. = exit

**rEF** Datum value [-999999, 999999]

Absolute reference value for the measuring system. This value is displayed by pushing \* key for 3 s. (displayed value includes previously set offset values).

\* = save, **P** = next parameter, **P** for 3 s. = exit

**OFS1** Offset1 value [-999999, 999999]

First offset value (e.g. tool correction). This value is added to actual value (see 6.2.3.)

\* = save, **P** = next parameter, **P** for 3 s. = exit

**OFS2** Offset2 value [-999999, 999999]

Second Offset value. This value is added to actual value and OFS1.

\* = save, **P** = next parameter, **P** for 3 s. = exit

**OFS3** Offset3 value [-999999, 999999]

Third Offset value. This value is added to actual value, OFS1 and OFS2.

\* = save, **P** = next parameter, **P** for 3 s. = exit

When the setup is completed the display shows "rESEt"

Push \* key twice to reset the display and quit the setup. "donE" will be displayed.

Push **P** key quit the setup without resetting the display. "no rSt" will be displayed.

### 6.3.4 Parameter list MENU 2

**Ad xx** Device address [01, 31]

Setting of device address (only if ordered with serial interface (option I1).

For setting use ← and ↑ keys.

\* = save, **P** = next parameter

**H\_cntr** Hour meter (1/10 h)

Elapsed time indication (display connected to battery). Resolution is 1/10 hour (6 minutes).

\* = save, **P** = next parameter

## 7 - RS232 serial interface (option I1)

If the display is provided with RS232 serial interface, the following commands can be used.

### 7.1 RS232 parameters

9600 Baud, 8Bit, no Parity, 1 Stop bit, Xon/Xoff

### 7.2 Serial commands

Serial commands must have the following structure:

| **ADCMND=X**

where:

|: PC keyboard symbol

**AD**: device address (00 to 31) 2 digit

**CMND**: command (see command list)

**X**: value range (see command list)

Upon receipt of a wrong command the display will answer with the same command + ? and checksum (e.g. sent command: |02azs → answer |02azs?EF)  
Any common terminal program can be used for communication with LD140 (e.g. Hyperterminal).  
Commands will be send after confirmation by ENTER key (carriage return).

Answers are structured as follows:

**ADCMND:XXXXXXXXCK**

where:

**AD**: device address

**CMND**: command

**XXXXXXXX**: value

**CHKS**: checksum

The checksum is equal to the least significant byte of the summing the hex values of all characters transmitted.

#### Example:

The displayed position is 8,29. The position of device with address 01 is read by means of the |01TPOS command.

The answer is: 01TPOS:+000008299F

The sum of hex values of all characters is the following:

30+31+54+50+4F+53+3A+2B+30+30+30+30+30+38+32+39 = 39F

The least significant byte of 39F is **9F** which is the checksum.

## 7.2.1 Command list

(below the device address is indicated with **AD**)

### Zeroing of device address

|00RSET

Address of all connected devices is set to zero (0).

### Device address [1, 31]

|00INIT=X

Sets address of all connected devices to value X.

### Display device address

|00DADR

Displays device address until **P** key is pushed.

### Change device address [1, 31]

|ADRADR=X

Changes actual device address AD to X.

Answer : ADTADR:+XCHKS (CHKS is checksum and X is value).

### Read actual position

|ADTPOS

Reads actual position of device **AD** (resolution of value is 0,01mm or 0,001 inch depending on settings).

### Change counting direction [0, 1]

|ADRDIR=X

Sets counting direction.

**X=0** → **uP** = standard direction

**X=1** → **dn** = inverted direction

Answer: ADTDIR:+0000000XCHKS

### Read counting direction

|ADTDIR

Reads the actual counting direction.

**X=0** → **uP**, **X=1** → **dn**

Answer: ADTDIR:+0000000XCHKS

### Measurement unit [0, 5]

|ADRUNI=X

Sets the measurement unit and display mode.

**X=0** → **dEC** = decimal mode

**X=1** → **FrEE** = display with conversion factor

**X=2** → **dG1** = angular ( $-\infty..-0,1^\circ..0,0^\circ..+0,1^\circ..+\infty$ )

**X=3** → **dG2** = angular ( $..359,9^\circ..0,0^\circ..359,9^\circ..0,0^\circ..$ )

**X=4** → **IdEc** = decimal inch display mode

**X=5** → **lfrcf** = fractional (es.  $12.31.64 = 12''^{31/64}$ )

Answer: ADTUNI:+0000000XCHKS

### Read measurement unit

|ADTUNI

Reads the status of measurement unit.

Answer: ADTUNI:+0000000XCHKS

### Resolution [1, 5, 10, 50, 100, 500, 1000]

|ADRRES=X

Sets linear resolution in mm or *inch*.

**X=1** → 0.001/0.0001, **X=5** → 0.005/0.0005,

**X=10** → 0.01/0.001, **X=50** → 0.05/0.005,

**X=100** → 0.1/0.01, **X=500** → 0.5/0.05,

**X=1000** → 1/0.1

Answer: ADTRES:+XCHKS

### Read resolution

|ADTRES

Reads value of actual resolution (see values above).

Answer: ADTRES:+XCHKS

### Free conversion factor COn

[with FrEE 0,00001 - 1,00000 / with dG1, dG2 0,00001 - 9,99999]

|ADRFRE=X

Sets free conversion factor COn (see chapter 6.3.1).

Answer: ADTFCO:+XCHKS

### Read COn conversion factor

|ADTFCO

Reads value of actual COn factor.

Answer: ADTFCO:+00X.XXXXCHKS

### Display mm/inch display mode [0, 1]

|ADRMMI=X

Changes display mode from mm to inch.

**X=0** → mm, **X=1** → inch

Answer: ADTMMI:+0000000XCHKS

## Read mm/inch display mode

|ADTMMI

Reads status of mm/inch display mode.

X=0→ mm, X=1→ inch

Answer: ADTMMI:+0000000XCHKS

## Incremental measurement function [0, 1]

|ADRRLA=X

Enables incremental measurement function (key combination **P** and **\***).

X=0→ off, X=1→ on

Answer: ADTRAE:+0000000XCHKS

## Read incremental measurement

|ADTRAE

Reads status of incremental measurement function.

X=0→ off, X=1→ on

Answer: ADTRAE:+0000000XCHKS

## Incremental measurement [0, 1]

|ADRRLA=X

Sets from absolute display mode to incremental (relative).

X=0→ off, X=1→ on

Answer: ADTRAE:+0000000XCHKS

## Read incremental measurement

|ADTRLA

Reads status of absolute/incremental display mode.

X=0→ off, X=1→ on

Answer: ADTRLA:+0000000XCHKS

## Datum function [0, 1]

|ADRRSE=X

Enables Datum function (by pushing **\*** key).

X=0→ off, X=1→ on

Answer: ADTRSE:+0000000XCHKS

## Read Datum function

|ADTRSE

Reads status of Datum function.

X=0→ off, X=1→ on

Answer: ADTRSE:+0000000XCHKS

## Datum value modification [0, 1]

|ADRRFE=X

Enables Datum value modification (by key combination **P** and **↑**).

X=0→ off, X=1→ on

Answer: ADTRFE:+0000000XCHKS

## Read Datum value modification

|ADTRFE

Reads status of Datum value modification.

X=0→ off, X=1→ on

Answer: ADTRFE:+0000000XCHKS

## Offset function [0, 1]

|ADROFE=X

Enables Offset function (by key combination **P** and **←**).

X=0→ off, X=1→ on

Answer: ADTOFE:+0000000XCHKS

## Read Offset function

|ADTOFE

Reads status of Offset function.

X=0→ off, X=1→ on

Answer: ADTOFE:+0000000XCHKS

## Datum value [-999999, 999999]

|ADRREF=X

Absolute Reference value for the measurement system. (the value has resolution 0,01mm or 0,001 inch depending on the display settings).

Answer: ADRREF:XCHKS

## Read Datum value

|ADTREF

Reads actual Datum value.

Answer: ADTREF:XCHKS

## Offset1 value [-999999, 999999]

|ADROF1=X

Sets Offset1 (OFS1) value (the value has resolution 0,01).

Answer: ADROF1:XCHKS

## Read Offset1 value

|ADTOF1

Reads actual Offset1 value.

Answer: ADTOF1:XCHKS

**Offset2 value** [-999999, 999999]

|ADROF2=X

Sets Offset2 (OFS2) value (the value has resolution 0,01).

Answer: ADROF2:XCHKS

**Read Offset2 value**

|ADTOF2

Reads actual Offset2 value.

Answer: ADTOF2:XCHKS

**Offset3 value** [-999999, 999999]

|ADROF3=X

Sets Offset3 (OFS3) value (the value has resolution 0,01).

Answer: ADROF3:XCHKS

**Read Offset3 value**

|ADTOF3

Reads actual Offset3 value.

Answer: ADTOF3:XCHKS

## 8 - Cut-out

### 8.1 LD140 and LD142

Provide a 94 x 68 mm (w x h) cut-out.

### 8.2 LD141

Check details on product catalogue.

Rev.	Man.Vers.	Description
0	1.0	1^ issue
	4.1	SW + Manual update
3	4.2	Chap.5 correction
4	4.3	Reset function correction (chap. 6.2.1)



**LIKA Electronic**

Via S. Lorenzo, 25 - 36010 Carrè (VI) - Italy

Tel. +39 0445 382814

Fax +39 0445 382797

Italy: eMail [info@lika.it](mailto:info@lika.it) - [www.lika.it](http://www.lika.it)

World: eMail [info@lika.biz](mailto:info@lika.biz) - [www.lika.biz](http://www.lika.biz)