

MD100D

DIGITAL LENGTH STOP

USER MANUAL

Version 20230901

kentuckygauge.com



Table of Contents

1. Technical Specifications	2
2. Safety Instructions and Obligations	3
2.1. General safety	3
2.2. Owner obligations	3
2.3. Operator obligations	3
2.4. Intended use	3
3. Component Identification	4
4. Installation	5
4.1. Mounting the guide rail	5
4.2. Setting the zero	6
4.3. Changing MD100D orientation	7
5. DRO Operation	8
5.1. DRO button identification	8
5.2. Restoring factory parameters	9
5.3. Setting the datum	10
5.4. Referencing the system/zeroing the system	10
5.5. Changing the unit of measure	10
5.6. Battery replacement	11
5.7. RS232 port	12
6. Maintenance requirements	13
6.1. Maintenance schedule	13
6.2. Lubricants and detergents	13
6.3. Guide rail	13
6.4. Magnetic tape	14
6.5. Carriage	14
6.6. Sensor alignment	15
7. Troubleshooting	16
8. Parameter List	17
9. Warranty	21

1. Technical Specifications

Resolution	0.001", 0.01mm, 1/64"
Accuracy	±0.001" per foot of measure
Repeat accuracy	±0.001"
Operating temperature range	32°-122°F
Protection level	IP60 DRO (front) IP67 scale
Max measuring speed	16 feet per second
Power supply	(1) C battery

This MD100D has been tested by Kentucky Gauge to meet or exceed the performance specifications listed above in accordance with length measuring equipment traceable to master standards at the National Institute of Standards and Technology (NIST).

2. Safety Instructions and Obligations

2.1. General safety

Operators of the MD100D should always be cognizant of their surroundings. The MD100D may be in the vicinity of many hazards that require the operator's attention. Additionally, these machines may be used to measure heavy parts and general precautions should be taken to minimize the chances of crushing or pinching hazards between the stop plate and the item being measured, or the item to be measured and the guide rail. In addition to these safety concerns specific to the MD100D, all shop and/or organizational safety rules should always be followed while working with your MD100D.

2.2. Owner obligations

The owner agrees to only allow the MD100D to be used by qualified and trained persons who have read and understand this instruction manual.

2.3. Operator obligations

Before operating, all persons working with this gauge agree to familiarize themselves with the machine and this instruction manual. Each operator is responsible for following all safety guidelines and for the safe and proper operation of the MD100D.

2.4. Intended use

The only acceptable use for the MD100D is as a length stop system. Any other use is not intended and is a misuse of the measuring system. Hymark is not liable for any damages resulting from misuse.

Intended use also means:

- Following all safety precautions mentioned in this manual
- Following the maintenance and inspection procedures as mentioned in this manual

3. Component Identification

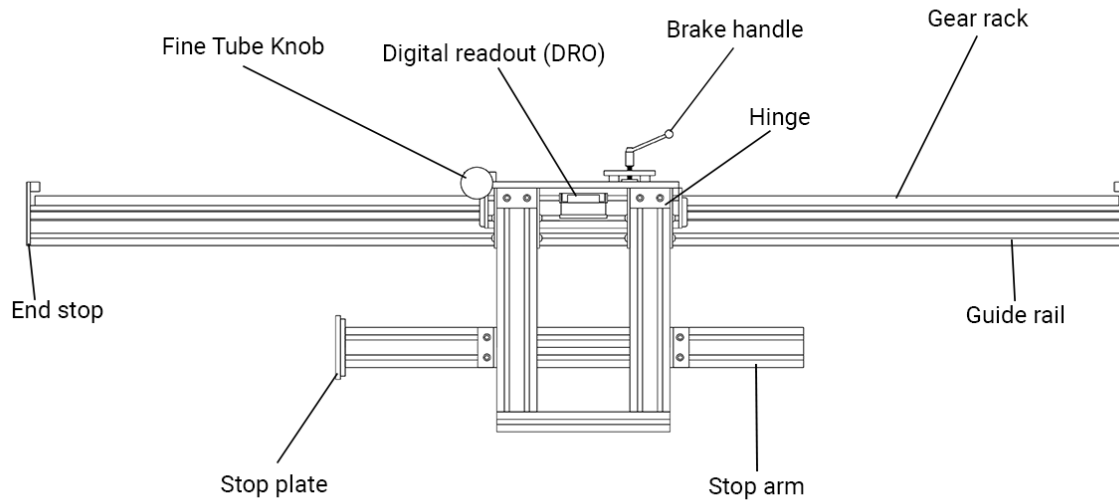

Note: DRO is powered by (1) C battery. The battery will need to be replaced approximately every 9-12 months depending on use and battery capacity. An industrial grade battery is recommended for maximum battery life.

An inactivity timer can be set to automatically power off display. Refer to the Menu 2 parameter list in Section 8 for timer settings. The timer setting will leave the microcontroller powered on to maintain accurate positioning.

4. Installation

4.1. Mounting the guide rail

The MD100D can be mounted to nearly any table or fixture using the t-slotted guide rail. The table below shows the most common methods used for installing the MD100D.

Hardware required:

M8 t-nuts (supplied)

Standoffs and M8x40mm SHCS (supplied)

Angle brackets (optional, not supplied)

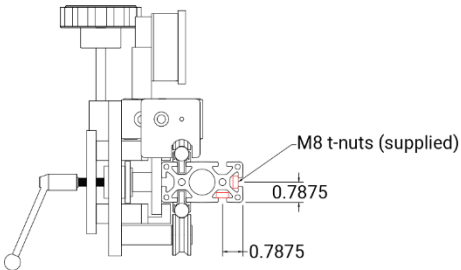
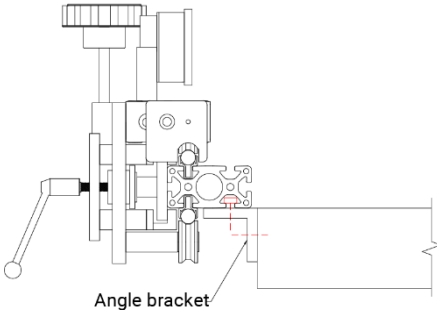
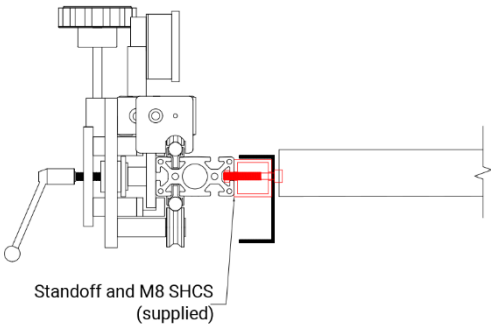
 <p>M8 t-nuts (supplied)</p> <p>0.7875</p> <p>0.7875</p>	<p>Mounting Dimensions</p> <p>The 40mm x 80mm guide rail has two available slots for mounting.</p> <p>When mounting the MD100D, the stop plate needs to be in position to function with your production equipment.</p> <p>It is common for the MD100D guide rail to function as a fence when using the bottom slot for mounting.</p>
 <p>Angle bracket</p>	<p>Solid Flat Table</p> <p>When mounting to a solid flat table, angle brackets can be used to mount the MD100D guide rail to the backside of the table.</p> <p>Screw spacing of 18-24" is recommended.</p>
 <p>Standoff and M8 SHCS (supplied)</p>	<p>Roller Conveyor</p> <p>When mounting to a roller conveyor, a standoff is needed to mount to the inside of the conveyor channel. Standoff size will depend on conveyor size. A 1.5" square standoff is included.</p> <p>The guide rail can also be mounted to the topside of the conveyor frame using the bottom slot.</p> <p>Screw spacing of 18-24" is recommended.</p>

4.2. Setting the zero

Before the MD100D can be put into production, the DRO must be referenced to your production equipment tooling to measure accurately. Setting the zero refers to the process of setting the initial displayed reading on the DRO to a known distance from the production equipment tooling.

Examples

In a sawing application, the DRO must be zeroed to the saw blade.

In a drilling application, the DRO must be zeroed to the center of the drill chuck/collet/drill bit.

In a punching application, the DRO must be zeroed to the center of the punch tooling.

Note – It is possible to set the zero on a saw blade by sliding the stop plate to the saw blade and setting the DRO to zero. Although this is a quick method setting the zero, it does not consider the outermost edge of the saw blade teeth or any potential saw blade runout.

The best method for setting the zero is to use the MD100D to make a sample part and input the measurement of sample part into the DRO using the set datum function to set a reference point (refer to Section 6.3 and 6.4). Figure 5 shows an example of setting the datum in a sawing application.

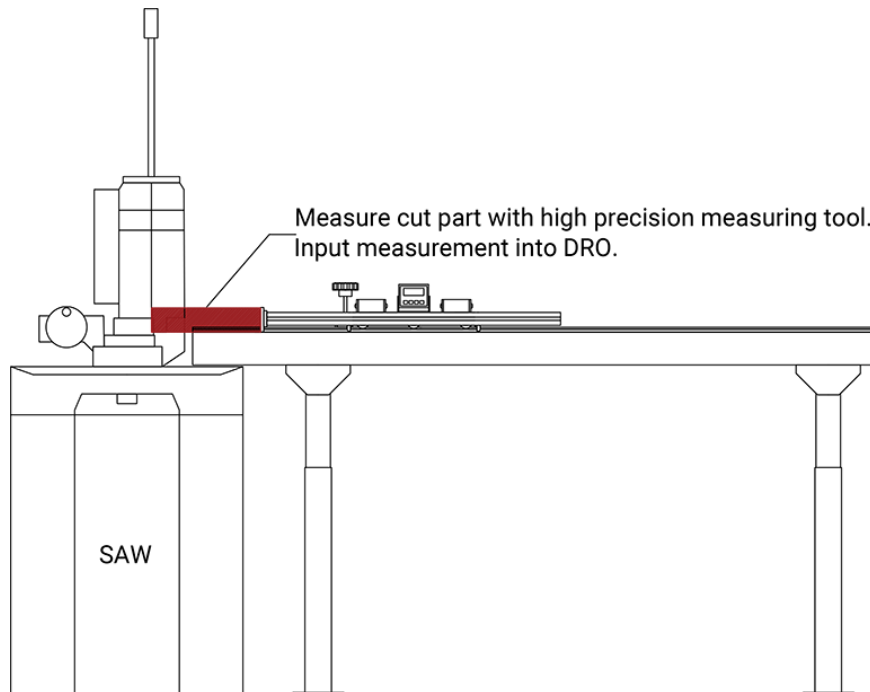

Figure 5

Once the MD100D is accurately referenced to the equipment, the MD100D can be put into production to help you improve your part accuracy and reduce waste caused by mismeasurements.

Note – The stop arm is adjustable and can be adjusted by loosening the cap screws on the angle mounting brackets to slide the arm closer to the production equipment to maximize MD100D travel capacity.

It is recommended to make a few additional sample parts using scrap material to ensure the MD100D is measuring accurately. Refer to Section 7 to troubleshoot accuracy issues.

4.3. Changing MD100D orientation

Each MD100D will ship as a right-hand system unless specified as a left-hand system – the DRO will read from left to right. However, the MD100D can quickly be changed to a left-hand system in two simple steps:

1. Remove the arm and mount in the opposite direction using the cap screws holding the arm on angle brackets.
2. Change the direction parameter in the DRO.

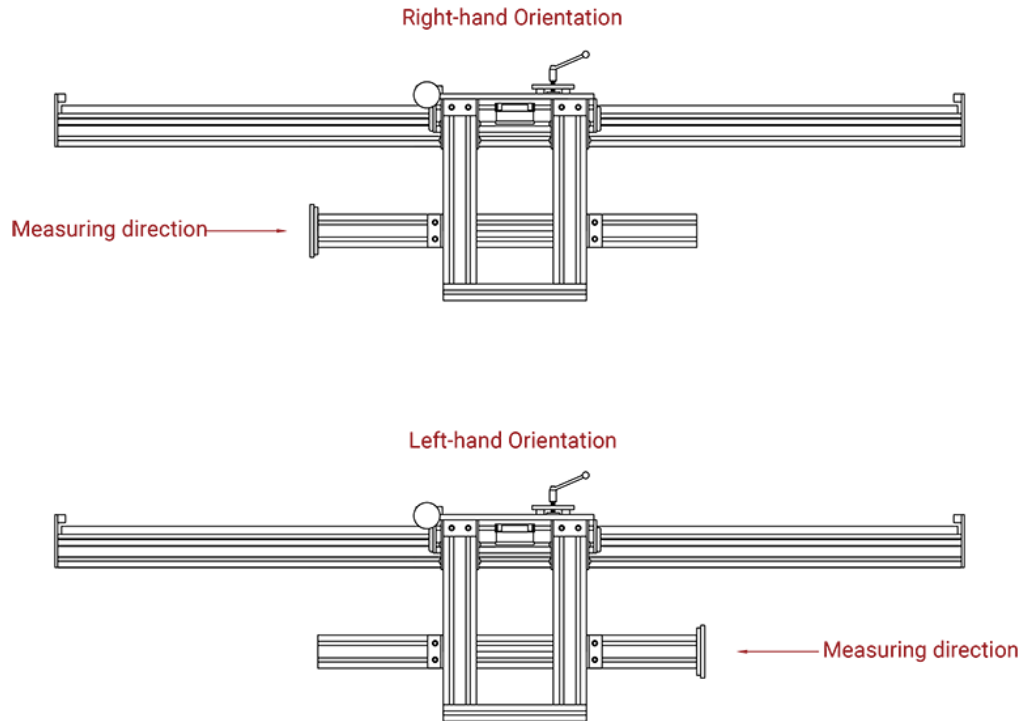

To change the direction parameter in the DRO:

- Hold down **SET** for 3 seconds to enter parameter mode, the DRO should display "SETUP"
- Press **ADJ**, the DRO should display "Unit"
- Press **SET** four times, the DRO should display "dir"
- Press **SET** again, DRO should display its current setting ("uP" is the factory default setting)
- Press **ADJ** to adjust the direction parameter setting
 - "uP" = right-hand orientation
 - "dn" = left-hand orientation
- Press ***** to save, "dn" will stop flashing
- Hold down **SET** for 3 seconds to exit parameter mode
- Slide the carriage in both directions to ensure the DRO is counting in the desired direction.

5. DRO Operation

5.1. DRO button identification



SET: Set (programming/change parameters)

ADJ: ADJ (increase value of selected digit)

<: Shift cursor left (select digit)

*****: Save (save data)

5.2. Restoring factory parameters

If your DRO parameters are inadvertently changed and you need to reset them, use the following procedure to restore the factory parameters:

- Hold down **SET** for 3 seconds to enter parameter mode, the DRO should display "SETUP"
- Press **ADJ**, the DRO should display "Unit"
- Press **SET** again to begin setting parameters back to default
- To navigate through the parameters:
 - Press **SET** to scroll from one parameter to the next
 - Press **SET** a second time and the current parameter value will flash on the display
 - Press **ADJ** to change the value for that item
 - When the correct value is set, press ***** to save
 - Press **SET** to move on to the next parameter
- Continue following these steps to set each parameter until you have made it through all parameters. After the final parameter, the DRO will return to its home screen. You can now zero or datum your MD100D then you are ready to measure. See section 5.3 for setting the datum.

The table below contains the factory default values:

Parameter	Value
Unit	1dEc
rES	0.001
dir	uP
F_nn1	yES
F_rEL	No
F_rST	yES
F_rEF	yES
rEF	000.000
F_oFS	No
rESET	No rSt

Note – For more explanation as to what other parameter options are available, see the parameters list at the end of this manual (Section 7).

5.3. Setting the datum

The datum is the value that the DRO resets to when referencing the MD100D. From the factory, the datum value is set to 0. To change the datum:

- Press **SET** and **ADJ** on the DRO simultaneously (the datum value will begin flashing)
- Use **<** to move through the digits (selected digit will flash) and **ADJ** to change the value for that digit.
- Once you have the DRO showing the desired datum, press ***** to save the changes and **SET** to return to the measurement screen.
- Now, when you reference your MD100D, it will reset to the datum instead of to 0.

Note – If pressing **SET** and **ADJ** simultaneously does not take you to the screen to change the datum, enter the parameters menu (as detailed in section 5.2) and make sure "f_rEF" is set to "yES".

If you prefer to always zero your MD100D, this value should be left at 0.000.

5.4. Referencing the DRO/zeroing the DRO

Referencing the system refers to resetting the DRO to the datum value. Refer to Section 5.2 for the recommended method of referencing the DRO.

Once the MD100D carriage is in the same position as the datum value:

- Hold down ***** until the DRO displays "rESEt"
- Press the ***** button again, the current measurement will begin to flash
- Press ***** again and the system will reset to the datum

Making a sample part using the MD100D and setting the datum value to the measurement of the sample part is the most accurate method of referencing the DRO.

5.5. Changing the unit of measure

Your MD100D can measure in both inches and millimeters. Operators can quickly switch back and forth using the following procedure:

- Hold down **<** for 3 seconds
- The DRO should change from displaying inches to millimeters or vice versa. Check the lower right-hand corner to see which unit is being displayed

Note – If the unit of measure does not change, check your parameters to ensure that the "F_nn1" parameter is set to "yES".

5.6. Battery replacement

The battery is located on the rear of the DRO behind a plastic cover. To remove the cover, push in on the ends and pull straight out.

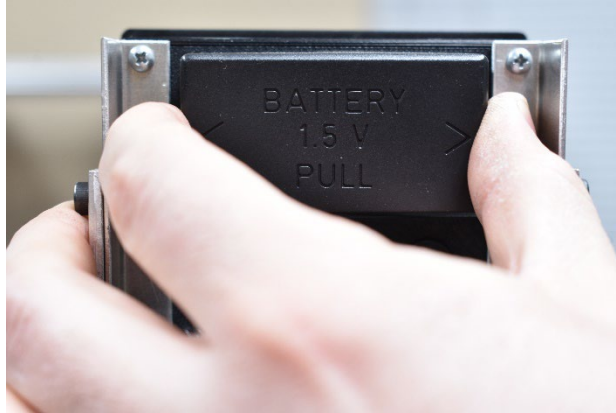

With the cover removed, you can see that the battery is held in by two plastic fingers, one on top and one on the bottom.

Push one of these fingers away from the battery while removing the positive end, as shown.



Pivot the battery from the negative end until it clears the plastic fingers and can be fully removed.

Note – During battery replacement, you should never use tools to remove the battery or pry against the DRO housing. This can result in the battery compartment pulling loose from the DRO or the solder joints between the battery connectors and the circuit board being pulled loose. For proper battery removal push out on the tabs securing the battery while pulling out on the positive end and it will come free.

Damage caused by improper battery removal will not be covered under warranty.

5.7. RS232 port



Your DRO is equipped with an RS232 port below the battery compartment. This port allows you to export data directly from your DRO to your computer via one of two optional SPC accessories. Hymark offers both wireless and wired SPC accessories that enable the SPC output function of the MD100D to transmit data to a PC by pressing **SET**. For more information or to purchase one of these devices please visit our website at kentuckygauge.com



SPC Cable



Wireless SPC

6. Maintenance Requirements

6.1. Maintenance schedule

See Section	Component	Clean	Lubricate	Adjust
4.3	Guide Rail	X	--	--
4.4	Magnetic Scale	X	--	--
4.5	Carriage	X	--	--
4.6	Sensor	X	--	O

Legend: X – Daily O – As needed -- Not required

6.2. Lubricants and detergents

Detergent

- Use commercially available detergents
- Do not use any acids or alkaline solutions
- Do not use any high-pressure water jet cleaners

6.3. Guide rail

Remove chips, grease and any other items that would be deemed in the pathway of, or cause an unwanted obstruction to, the carriage. This should be done several times per day if the machine is in heavy use.

6.4. Magnetic scale

The magnetic scale is what the sensor reads to produce the measurements on the MD100D. It is located on the backside of the guide rail and should periodically be cleaned and checked for damage.

- Remove chips and grease on the magnetic scale and between the sensor and scale. This should be checked daily to ensure there is no development of debris or obstructions. If heavy chip or debris accumulation occurs, increase frequency to accommodate suitable maintenance measures.
- The sensor-to-scale gap should be within the range of 0.003" to 0.030" (sensor gap and alignment covered more in depth in section 4.7).

Chemical Resistance

<i>Acetone</i>	**	<i>Ketone</i>	***
<i>Acetylene</i>	**	<i>Mineral oil</i>	*
<i>Benzene</i>	***	<i>Seawater</i>	**
<i>Gasoline</i>	**	<i>Steam heat</i>	*
<i>Heptane</i>	***	<i>Thinner</i>	***
<i>Kerosene</i>	*	<i>Turpentine</i>	**
* - Little-to-no effect ** - Low-to-moderate effect ***- Severe effect			

6.5. Carriage

- Remove chips, grease and any items on the measuring surface that would be deemed in the pathway of, or cause an unwanted obstruction to, the carriage or stop arm. This should be done several times per day if the machine is in heavy use.
- Ensure that the hardware connecting the stop arm to the carriage is secured. This may be checked on a quarterly basis or implemented in line with the standard preventative maintenance schedules for the other equipment in the facility.

6.6. Sensor alignment

Figure 3, below, depicts the proper sensor alignment for accurate measuring. The sensor and bracket should be tight, the sensor should be level with the scale, and there should be a uniform distance between the sensor and the scale 0.1-1.0 mm (0.003"-0.030"). If the sensor does not meet these criteria, follow the steps below to adjust it.

1. Slightly loosen the two M3 sensor mounting screws (figure 4).
2. Insert a feeler gauge with a thickness within the acceptable gap range between the sensor and the scale. Be sure that the feeler gauge is inserted far enough to maintain the proper gap throughout the full length of the sensor.
3. Push in the sensor so that it touches the feeler gauge and continue holding as you tighten the two M3 sensor mounting screws.
4. Remove the feeler gauge from between the sensor and the scale.
5. Zero or datum your DRO and, check various measurements to see if your MD100D is now measuring within spec.
 - a. If possible, make a test cut using the MD100D and measure the cut part using a Kentucky Gauge MMP Digital Measuring Machine or digital calipers to ensure the part measurement matches the displayed measurement on the DRO. If the measurement is incorrect, datum your DRO with this measurement and repeat this step. See section 6.3 for setting the datum.

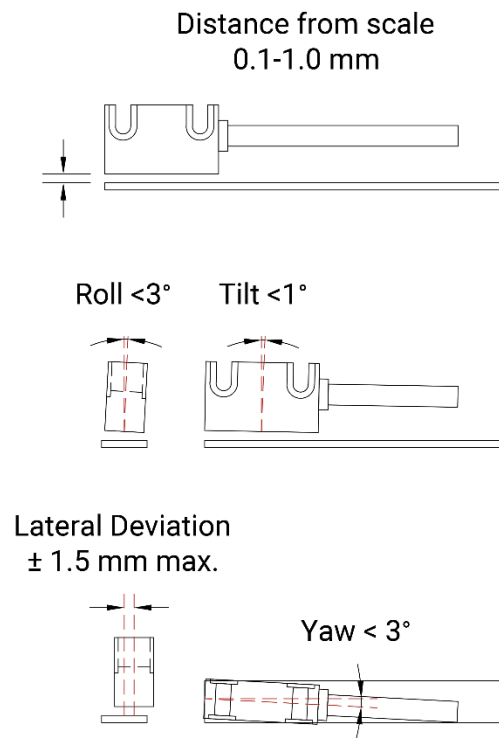



Figure 3



7. Troubleshooting

Problem	Solution
DRO will not power on	The DRO is constantly under power. If your DRO is not on the battery may be dead. Replace the battery. (Section 5.6)
DRO will not zero/reference	<p>If you cannot get your MD100D to zero or reference, most likely the "F_rST" parameter has been changed to "no". Follow the procedure for restoring factory parameters and change "F_rST" to "Yes".</p> <p>If your MD100D allows you to reset to zero but does not allow you to change the datum to reference the system to a different length, parameter "F_rEF" has been changed to "no". Follow the procedure for restoring factory parameters and change "F_rEF" to "Yes". (Section 5.2)</p>
When zeroing the system DRO resets to a value other than zero	If you are attempting to zero the system and your DRO resets but it resets to a value other than zero, a datum value has been entered in the DRO. To change the datum back to zero, press the SET and ADJ buttons at the same time. Change the displayed value to 0.000. Press the set button to exit. (Section 5.2)
DRO reading erratically or measurements are off varying amounts at various points	<p>Examine the magnetic scale on the rear of the guide rail for signs of damage.</p> <p>If there is no damage, check to see if your sensor is tight and your sensor-to-scale gap is within spec. (Section 4.7)</p>
Measurements are off a set amount the full measuring length	The reference/datum point was set incorrectly. Reference the MD100D (Section 5.4)

8. Parameters List



The following chart outlines all the possible options for the various parameters in the DRO. Some of these parameters could make your MD100D non-functional. Be sure you are familiar with how to return all parameters to the factory settings before experimenting with parameter options.

To access parameters, hold down  for 3 seconds, the DRO should display "SETUP".

- To access Menu 1: press 
- To access Menu 2: press 

Note – Factory MD100D settings are highlighted in Red and **Bolded**

Menu 1	
Parameter	Description
Unit	<p>Determines what type of measuring the DRO will perform (linear or angular) as well as, the unit of measure (inches, mm, degrees).</p> <p>DEC – Linear measurement display in decimal FrEE – Display with conversion factor dG1 – Angular display dG2 – Angular display IdEC – Inch display mode Ifrct – Fractional inch mode (all separated with decimals, 15 13/64" would display 15.13.64)</p>
CO _n	<p>Allows operator to set a free conversion factor to display non-metric units, angles, or used as a scaling factor to correct linear inaccuracies.</p> <p>Value range: FrEE = 0.00001-1.00000 dG1, dG2 = 0.00001 – 9.99999</p> <p><i>*parameter only available when Unit = FrEE, dG1, or dG2.</i></p>

rES	<p>Sets the resolution of the display.</p> <p>Options: Unit (dEC, FrEE, dG1, or dG2) – 0.001, 0.005, 0.01, 0.05, 0.1, 0.5, 1</p> <p>Unit (IdEC) – 0.0001, 0.0005, 0.001, 0.005, 0.01, 0.05, 0.1</p> <p><i>*parameter only available when Unit = dEC, FrEE, dG1, dG2, or IdEC</i></p>
Dir	<p>Sets the counting direction of the sensor.</p> <p>uP – up (standard counting direction) dn – down (inverted counting direction)</p>
F_nnl	<p>Enables switching back and forth from inches to millimeters by holding down .</p> <p>yES – enabled (holding  for 3 seconds changes the unit of measure) no – disabled (can only change unit of measure in parameters menu)</p>
F_rEL	<p>Enables the incremental measurement function.</p> <p>yES – Enabled (allows changing the DRO to incremental measuring by pressing  and  simultaneously) no – Disabled (DRO stays in absolute measuring)</p>
F_rSt	<p>Turns the referencing/zeroing function on or off.</p> <p>yES – Enabled (holding down  for 3 seconds will reference the DRO to the datum value or 0 depending on the setting of F_rEF) no – Disabled (DRO cannot be referenced)</p>
F_rEF	<p>Allows modification of the datum value the DRO references to by pressing  and  simultaneously.</p> <p>yES – Enabled (operator can change the datum and the DRO will reference to that value) no – Disabled (DRO will only reference to 0)</p>

<p>F_oFS</p>	<p>Allows adding offset values to the DRO measurements. OFS1 can be adjusted by pressing SET and < simultaneously. OFS2 and OFS3 can be adjusted in the parameter menu only. Operators can select which offsets to apply by pressing ADJ.</p> <p>yES – Enabled (operator can apply offset values to the DRO measurement) no – Disabled (operator cannot apply offset values to the DRO measurement)</p> <p><i>*If F_oFS is previously set to yES and a value is entered for OFS1, the value must be changed to 0 before changing F_oFS to "no" or the offset will continue to be applied.</i></p>
<p>rEF</p>	<p>This value is your datum (the value that the DRO resets to when * is held down for 3 seconds).</p> <p>Value can be changed either in parameters menu or by pressing SET and ADJ simultaneously.</p> <p>Value range (-999999 to 999999)</p> <p><i>*this parameter is only available if F_rSt is set to yES.</i></p>
<p>OFS1</p>	<p>This is the first offset value, it is added to the measured value. This value can be adjusted by pressing SET and < simultaneously.</p> <p>Value range (-999999 to 999999)</p> <p><i>*this parameter is only available if F_oFS is set to yES</i></p>
<p>OFS2</p>	<p>This is the second offset value, it is added to the measured value+OFS1. This value is only adjustable through the parameter menu.</p> <p>Value range (-999999 to 999999)</p> <p><i>*this parameter is only available if F_oFS is set to yES</i></p>
<p>OFS 3</p>	<p>This is the third offset value, it is added to the measured value+OFS1+OFS2. This value is only adjustable through the parameter menu.</p> <p>Value range (-999999 to 999999)</p> <p><i>*this parameter is only available if F_oFS is set to yES</i></p>

Menu 2

AD xx	<p>Sets device address for serial/network communication to remotely read and write parameter settings. Valid addresses are from 01 to 31.</p> <p>00 is reserved for broadcast mode.</p> <p><i>*Please contact your sales representative if serial/network communication is desired.</i></p>
H cntr	<p>Hour meter for battery. Displays elapsed time the inserted battery has been used in the DRO. Resolution is 1/10 of an hour (6 minutes).</p>
TIMER	<p>Sets the inactivity timer for automatically powering off display. After the set time of inactivity has elapsed, the display powers off but the microcontroller remains active to maintain accurate positioning. As soon as the sensor detects movement, the display powers back on.</p> <p>Available timer settings (minutes): 0, 1, 2, 3, 4, 5, 10, 15, 20, 25, 30.</p>

9. Warranty

Hymark warrants this product for a period of twenty-four (24) months from the date of shipment. During the warranty period, under authorization from Hymark, return component parts freight prepaid. The company will repair or replace, at its option, any part found to be defective in material or workmanship, without charge to the owner for parts, service labor, or associated shipping costs. This same protection will extend to any subsequent owner during the warranty period. It does not apply to damage caused by accident, misuse, fire, flood, acts of God, or from failure to properly install, operate, or maintain the product in accordance with the printed instructions provided.

This warranty is in lieu of any other warranties, expressed or implied, including merchantability or fitness for a particular purpose, which are expressly included. The owner agrees that Hymark's liability with respect to this product shall be set forth in this warranty, and incidental or consequential damages are expressly excluded.

Technical Support

Let us know how we can help! Our support technicians look forward to helping you with your Kentucky Gauge equipment.

By phone

270-228-2817

By email

info@hymark.net



Hymark Ltd
427 Bark Cove
Owensboro, KY 42303
270-683-3500

www.kentuckyguage.com